

1:12 Electric 4WD Climbing car

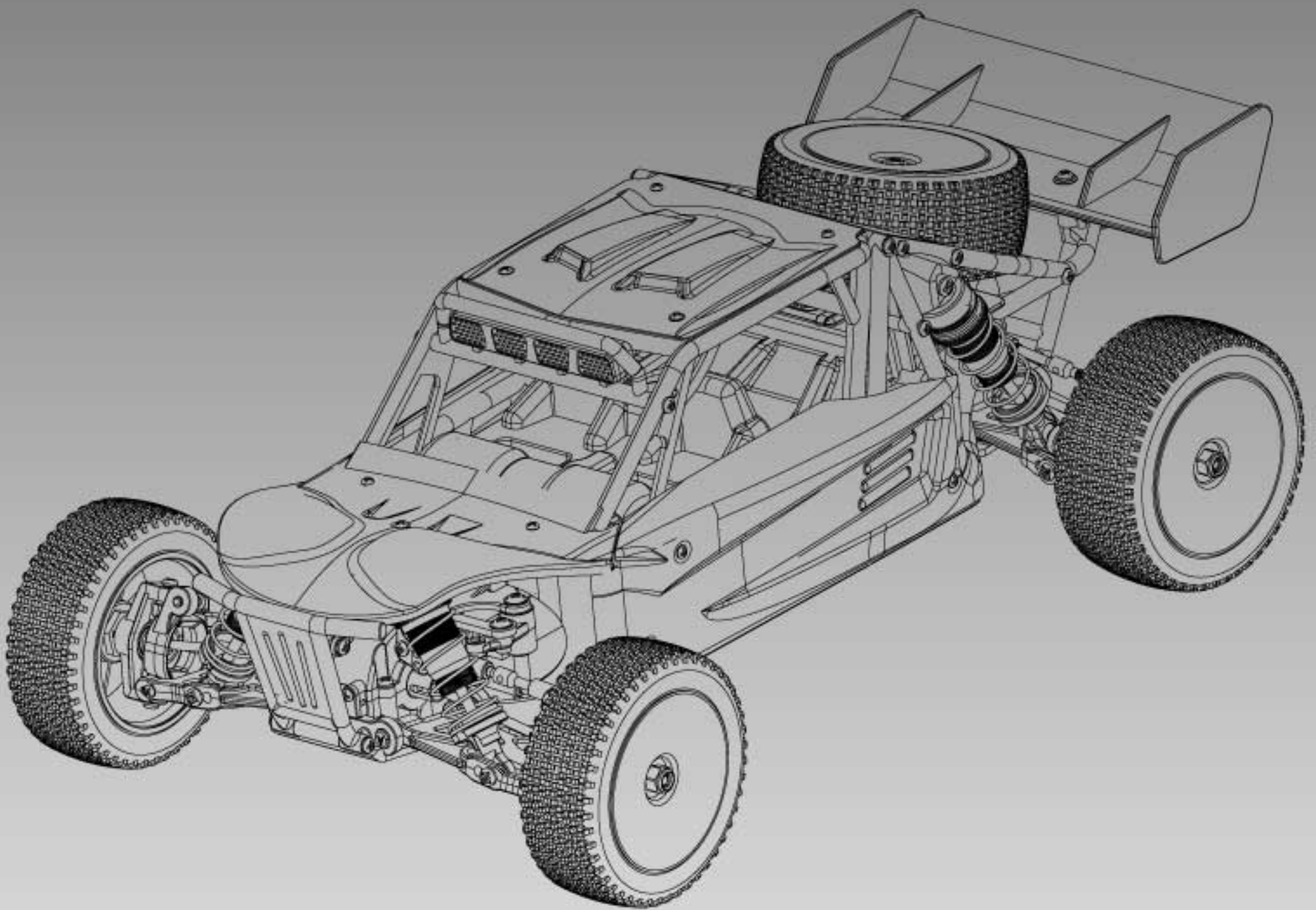

Caution: This model is not a toy, it is designed for user over 14 years of age.

Please use this instruction and the R/C system instruction at the same time.

The instruction is suitable for a type of model whose number is 124016

Safety and caution	1-2
Troubleshooting • Product introduction	2-3
Instruction of common tools and installation the electronic part...	4
Practice and maintenance.....	5
Assemble exploded view	6-15
Fittings view	16-20

Safety and Cautions

- *Never run the model on public roads or streets, as it could endanger traffic.
- *Never run the model in crowded areas, near or toward people or animals, to prevent property damage and/or personal injury.
- *Never run the model near rivers, ponds or lakes as to prevent R/C car from dropping into the water.
- *Make sure that no one else is using the same frequency as yours in your running area. Using the same frequency at the same time, whether it is driving, flying or sailing, can cause loss of control with R/C model, resulting in serious accidents.
- *To avoid a runaway R/C model or loss of control, always follow the procedure below:
 1. Fully extend transmitter antenna.
 2. Switch on transmitter.
 3. Switch on R/C model.
- *Follow reverse procedure to shut down.
- *Never touch or hinder rotating tire.
- *Never run R/C model in the rain or let run over puddles, as water may cause trouble with R/C model.
- *Motor and battery get very hot after running. Take care when handle them.
- *Retract transmitter antenna when not in use.
- *Remove the batteries from model and transmitter when they are not in use.



Cautions when handling batteries

- *Do not dismantle the battery or charger and do not cut any battery cables. This may cause short-circuit and/or damage to the product.
- *Change battery with compatible charger following proper procedure that is called out in the instructions. Do not modify charger or charge battery in improper way.
- *Do not recharge battery that is still warm from use as it may damage the battery. Allow the battery to cool off prior to recharging.
- *Make sure to disconnect charger cables from R/C model and electric outlet when not in use.
- *Remove transmitter battery when not using it for a long time as it may leak and damage transmitter when left for a long period.
- *Never incinerate used batteries, as they can explode causing serious accidents.



Safety precautions

Do not operate the model on public roads, in crowded places or near infants, it may cause accidents or injury.

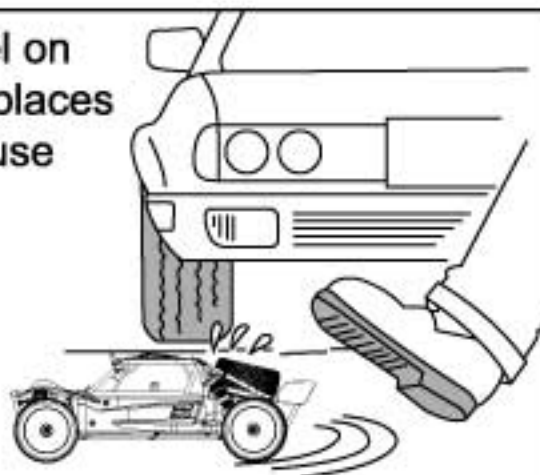

As the product includes small and sharp parts, assemble and store this product only in places out of the reach of children.



As the front end of the antenna may be dangerous, do not aim it toward faces.



During the car running and after, the motor will be hot. Please do not touch it until it has had time to cool down.



Don't use the same frequency with others at the same time. Or the car will lose control or even lead to serious accidents.



Troubleshooting

Description	Cause	Solution
The car does not operate at all.	Transmitter or receiver is off.	Turn on both transmitter and receiver.
	Batteries are not placed properly in the transmitter.	Place batteries in the transmitter properly.
	The drive battery is not charged enough.	Charge the drive battery.
The car does not follow your operation and control distance not enough long.	Someone else is using the same radio frequency as you are using.	Change your radio frequency to the one no one else is using, wait until the driver using the same radio frequency finishes driving, or drive your car at a different place.
	There is not enough power in the transmitter or receiver batteries.	Replace the transmitter batteries with new ones and charge the drive battery.
	Not tighten antenna on the transmitter/not fully extend antenna.	Make sure insert antenna into the transmitter and fully extend antenna.



CAUTION

- * Please observe the operation manual or packing explanation to install and use, and some parts should be installed by adults.
- * The product contains small parts, it may cause swallow or choke.
- * Never run an R/C model in the seep or rain, moisture areas, or it may cause the parts malfunction.
- * Please throw the wrapper in time to avoid danger for the children.
- * Regularly examine for damage to the charge, wire, plug, bodyshell or other parts. In the event of any damage, it must not be used until the damage has been repaired.
- * The charge, battery box and battery must insert with the appointed power source of product symbol same.
- * This product must only be used with the original collocation charger.
- * The product is contains the functional outshoots are may be dangerous to the children.

Proportional R/C Using Instruction

- ① Turn left the steering wheel, the car will turn left. Turning left angle can be adjusted by the degree of wheel twisting.

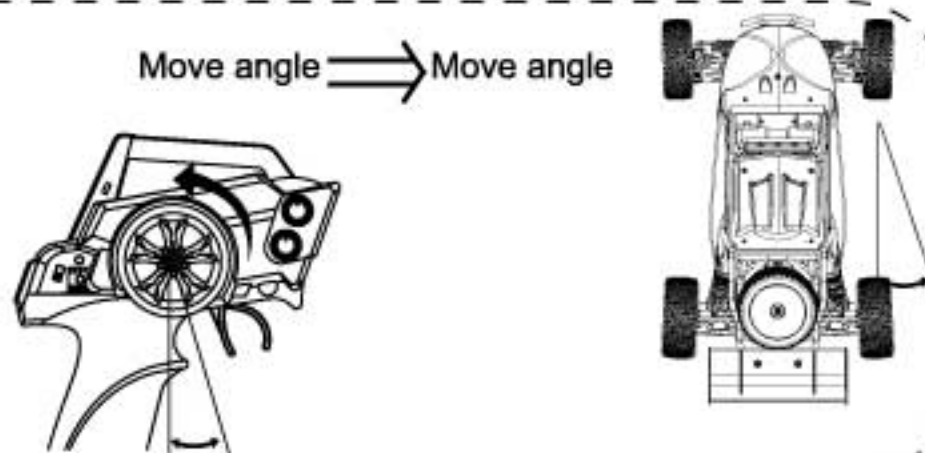

- ② Turn right the steering wheel, the car will turn right. Turning right angle can be adjusted by the degree of wheel twisting.

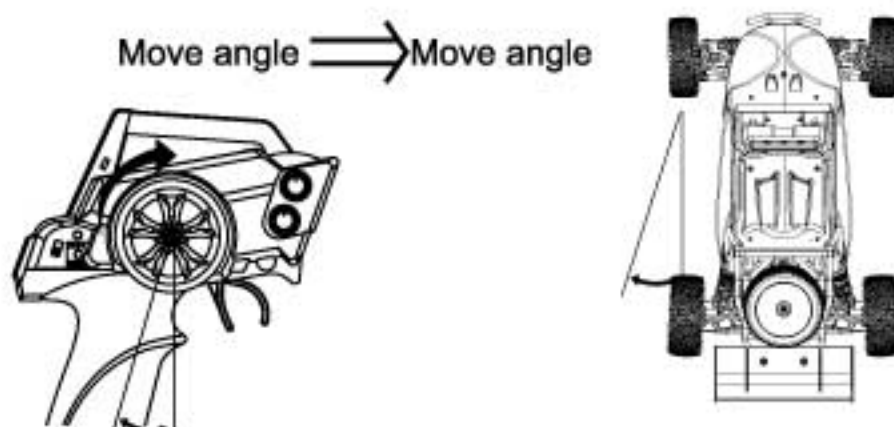

- ③ Pull the throttle trigger backward, the car will forward. Adjusting the angle of throttle trigger can adjust forward speed of the car. During the car forward, quickly push the trigger forward to stop it.

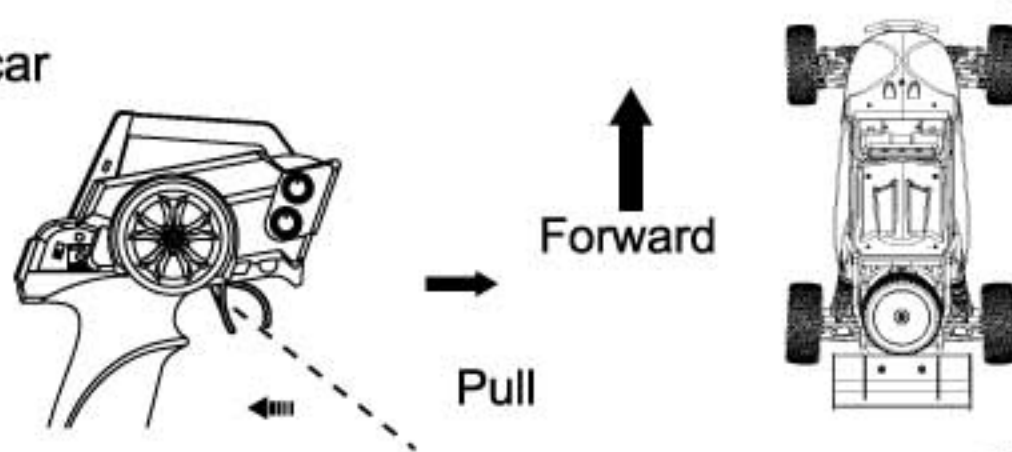

- ④ Loosen the trigger to make it return the neutral position when brake. Push the throttle trigger forward, the car will backward. Adjusting forward angle of throttle trigger adjust backward speed of the car.

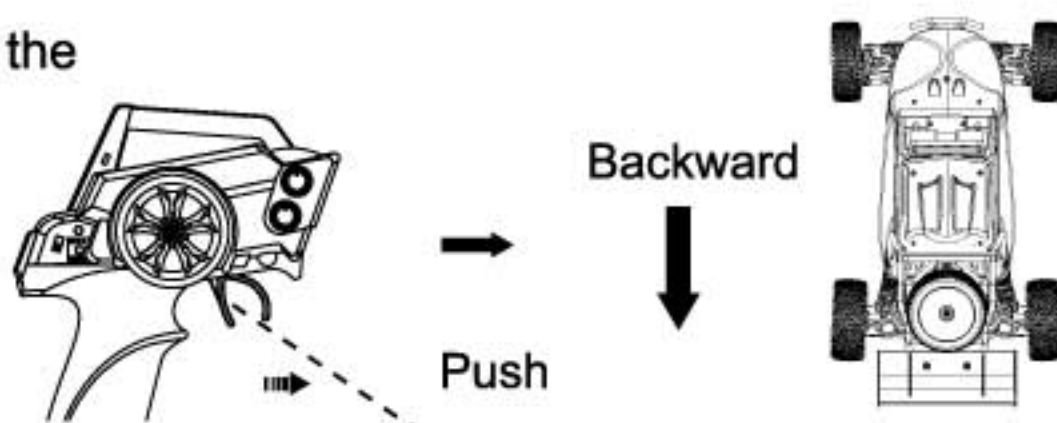

Introduce the common tools and assemble the electron parts

Tools needed for assembly

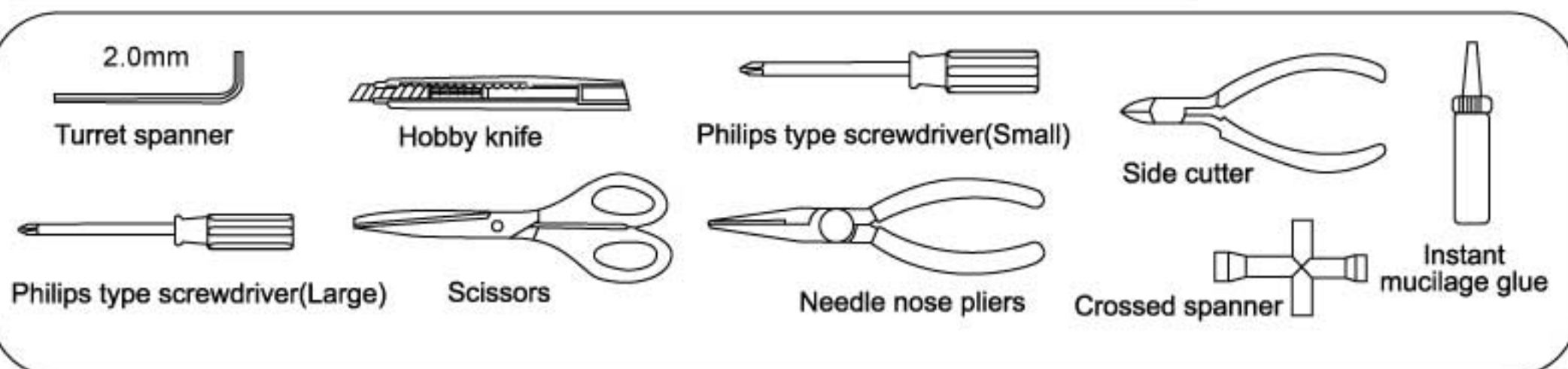

PRACTICE AND MAINTENANCE

Operating program

1. Turn on the power switch **1** on the remote and make sure the power indicator **2** flashes red, then turn on the model car's power switch.
2. The model car on the shelf, gently hook remote control on the trigger **3** to observe whether the car can move forward and backward.
3. Turn the remote control steering wheel **4** to the left or right and make sure that the front wheel's steering follows the command.
4. The model car on the ground, and standing behind the model car, gently hook the remote control throttle trigger **3**, if the model car does not go straight, rotate the remote control front wheel trim **5**, the model car to the right side, the front wheel Turn the trim to the left, the model car leans to the left, and the front wheel trims to the right to rotate until the model car can go straight.
5. Throttle speed adjustment **6** can adjust the model car speed, rotate to the right, hook the trigger model car speed becomes faster, turn left, hook the trigger model car speed becomes slower.
6. OK, ready to run.

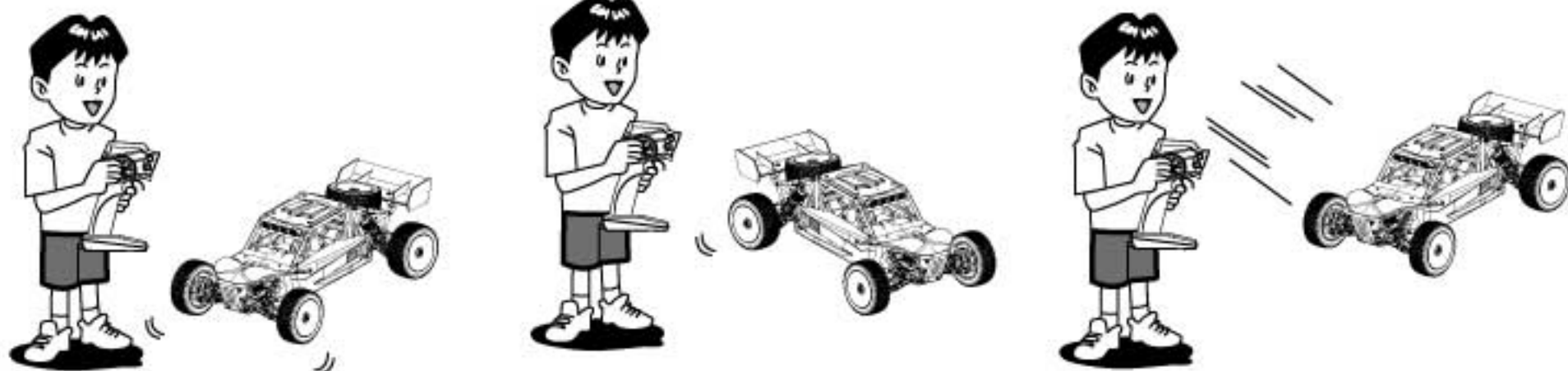
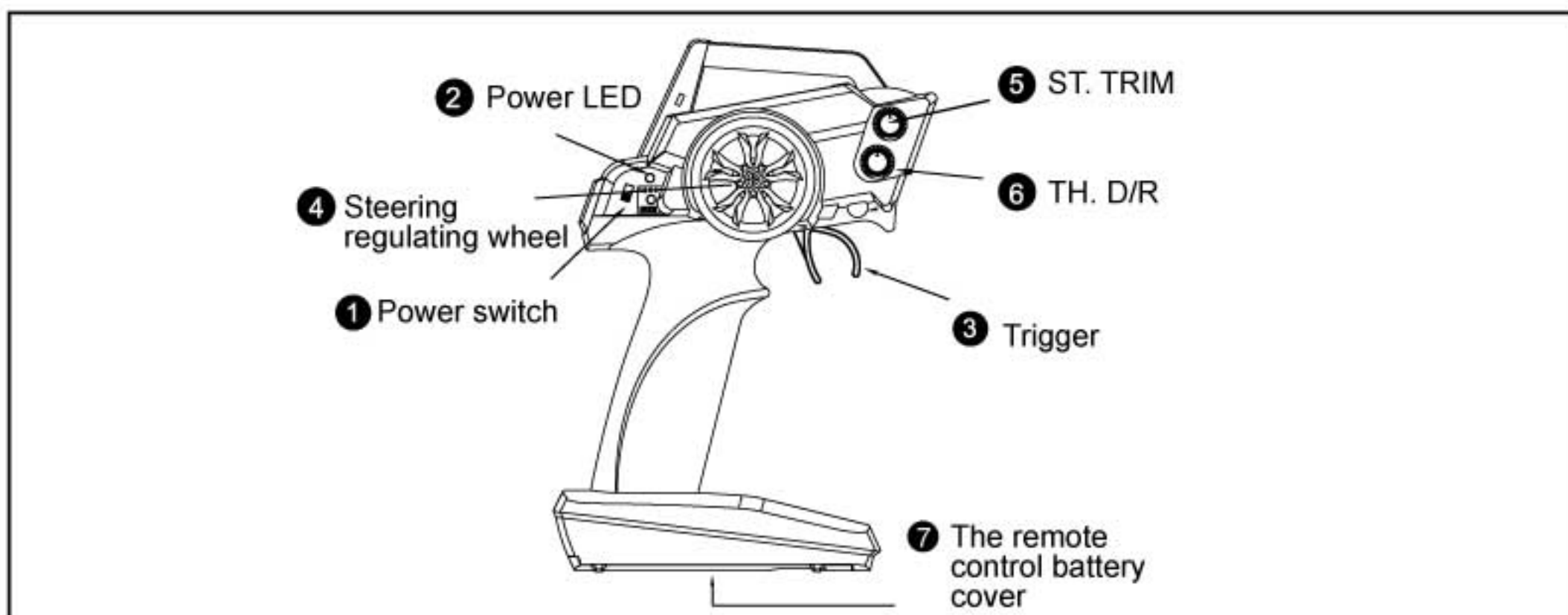

Practice

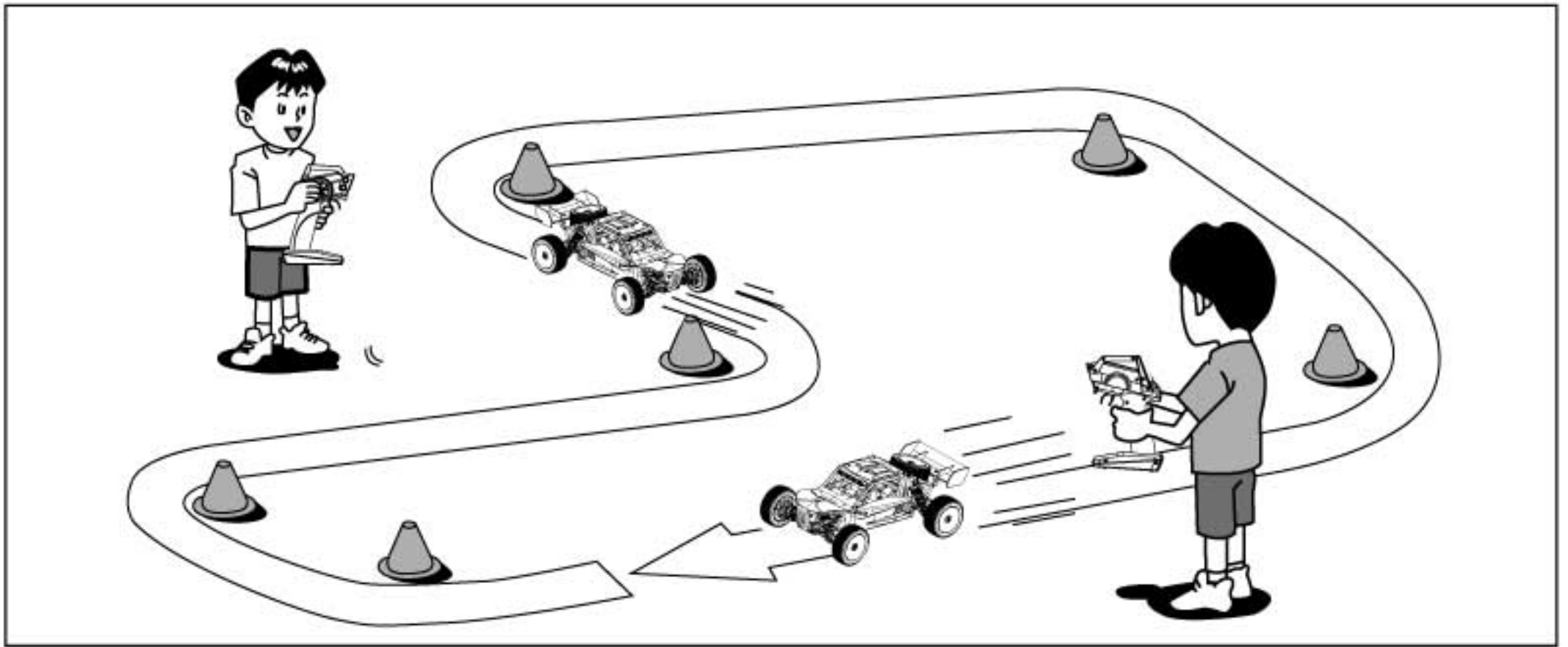

Let's practice! Make R/C car circuit at a wide and safe location using corner pylons (separately available), empty cans or such. Running fast at straight section and slow down at curved section is a basic speed control technique useful when driving R/C car.

Maintain

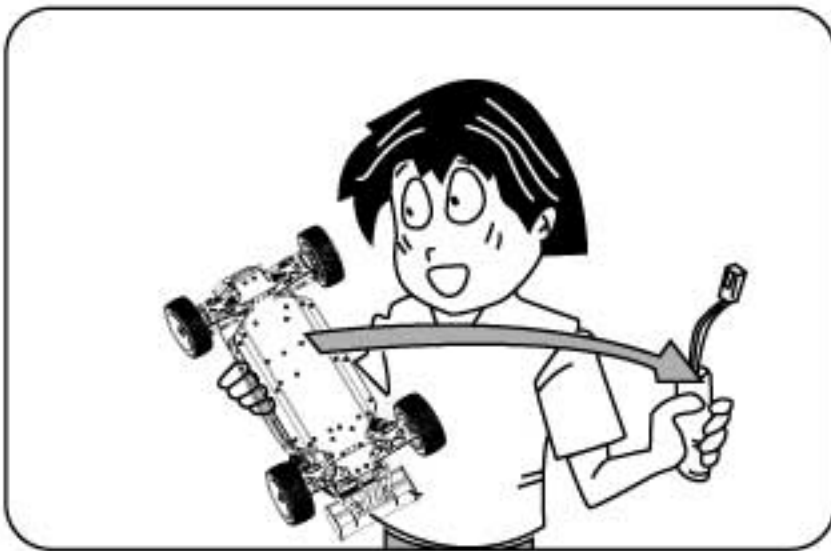

When the car is not in use, you should remove the battery from the car.

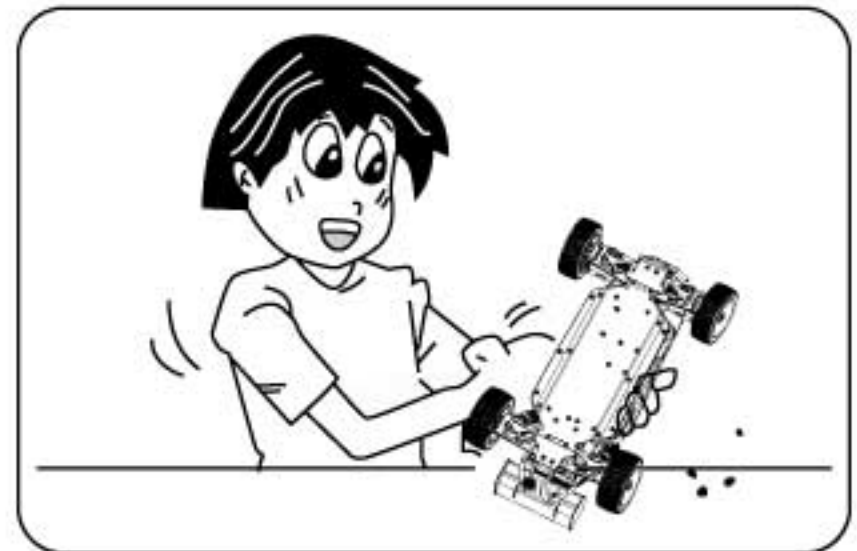

Completely remove sand, mud, dirt etc.

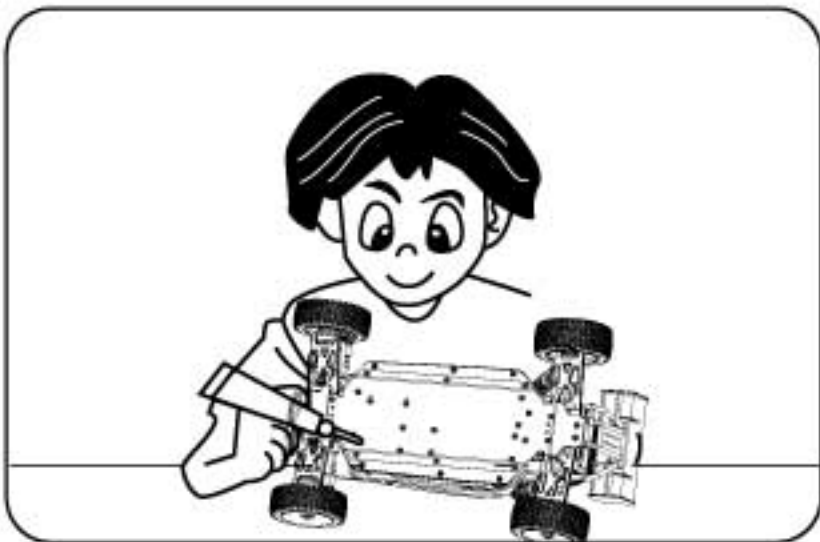

Metal outside should apply the rust prevention oil.

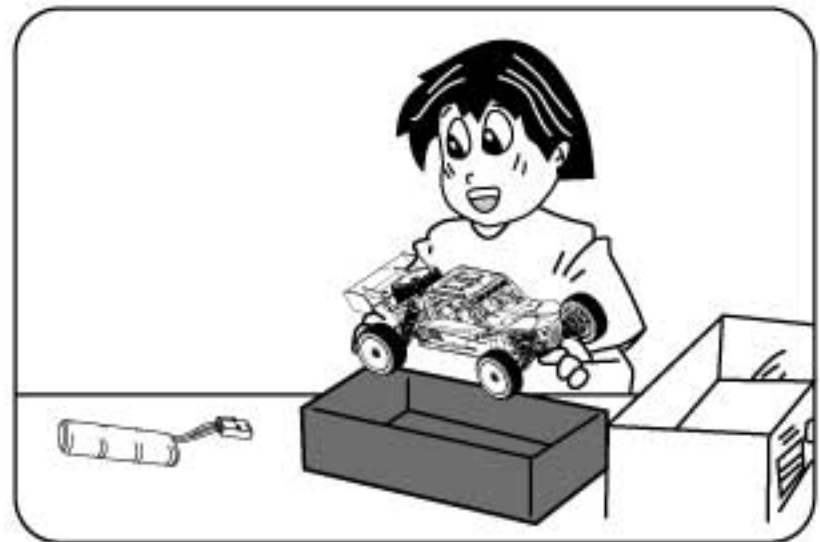

Store the car and batteries separately when not in use.

Assembly Exploded Diagram

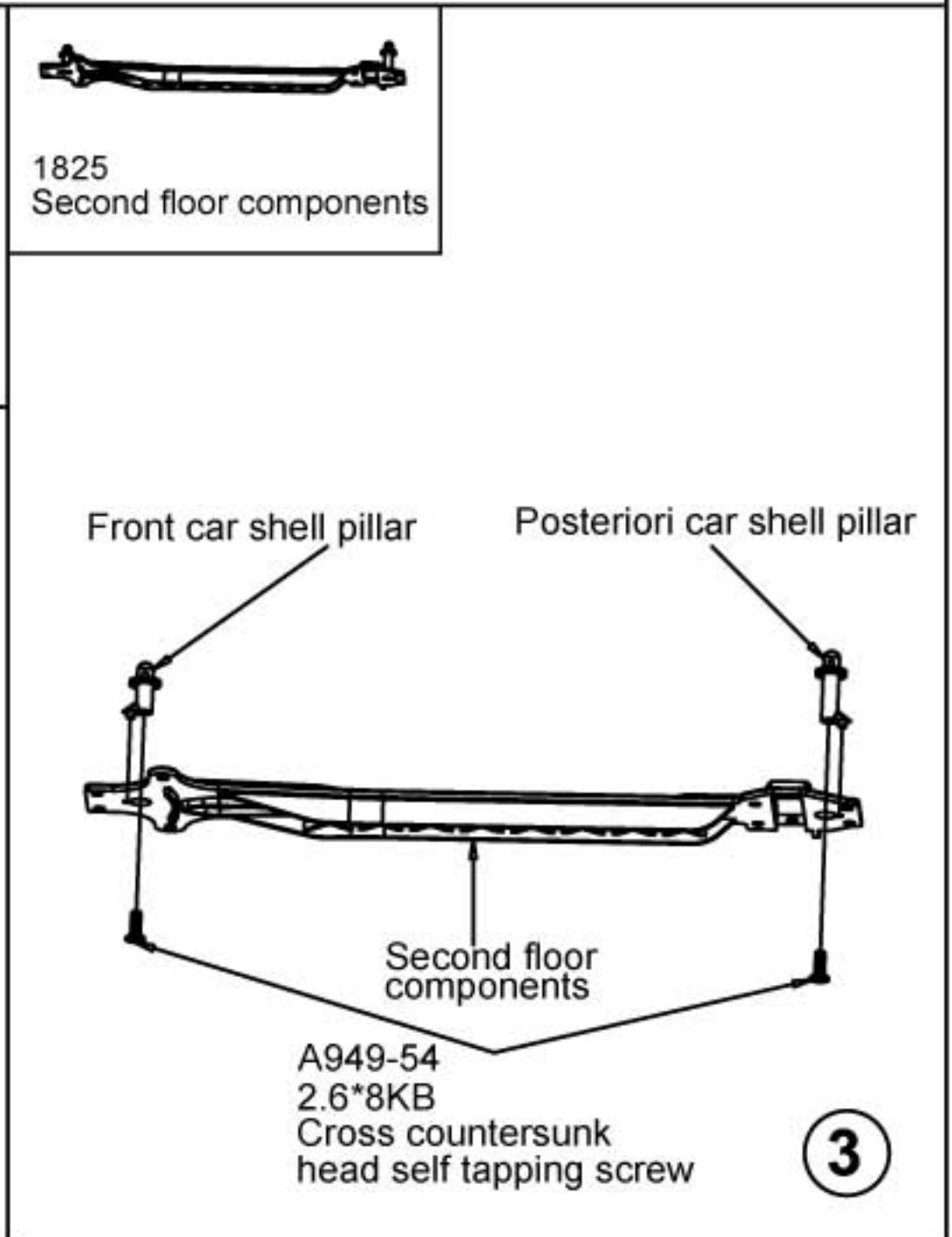
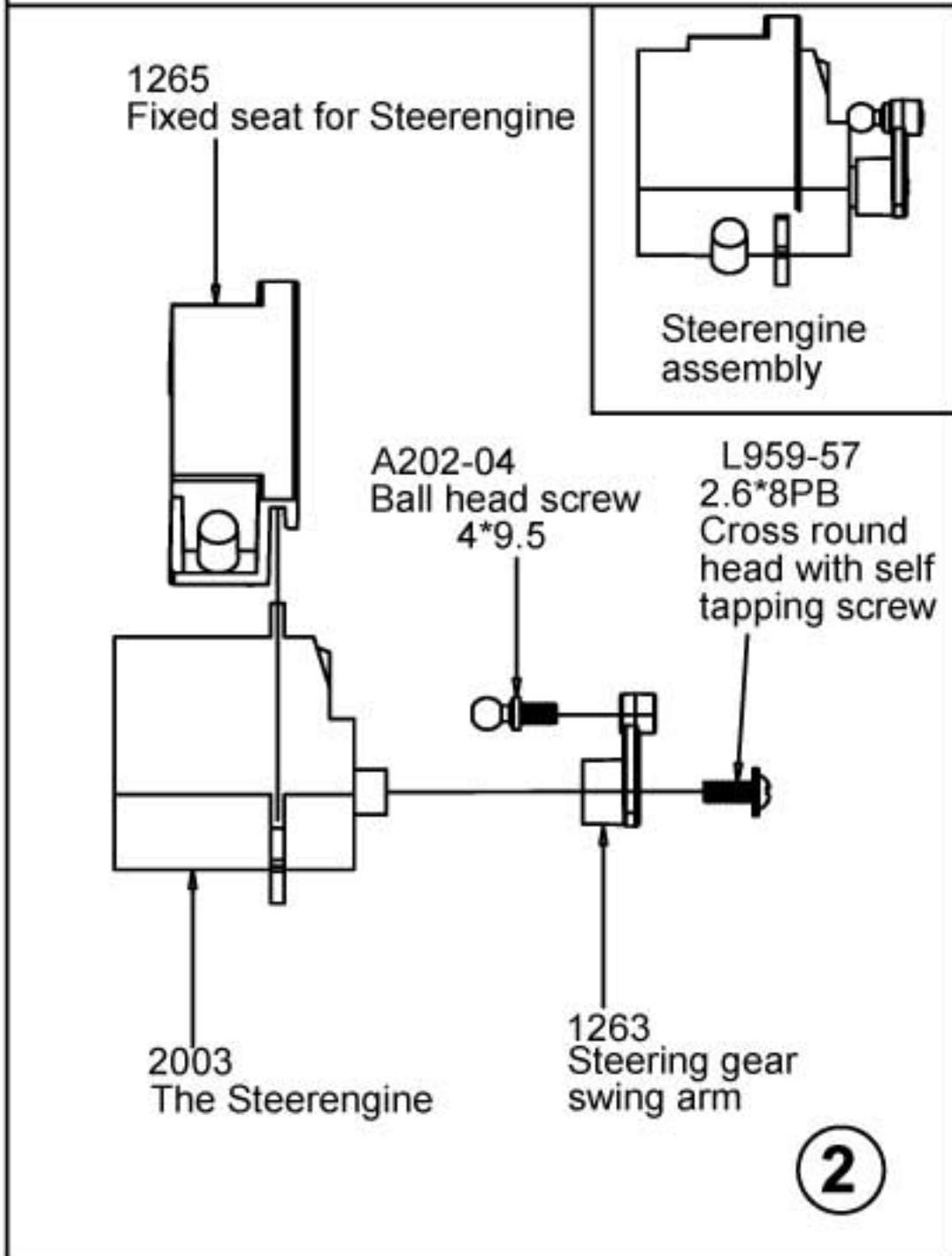
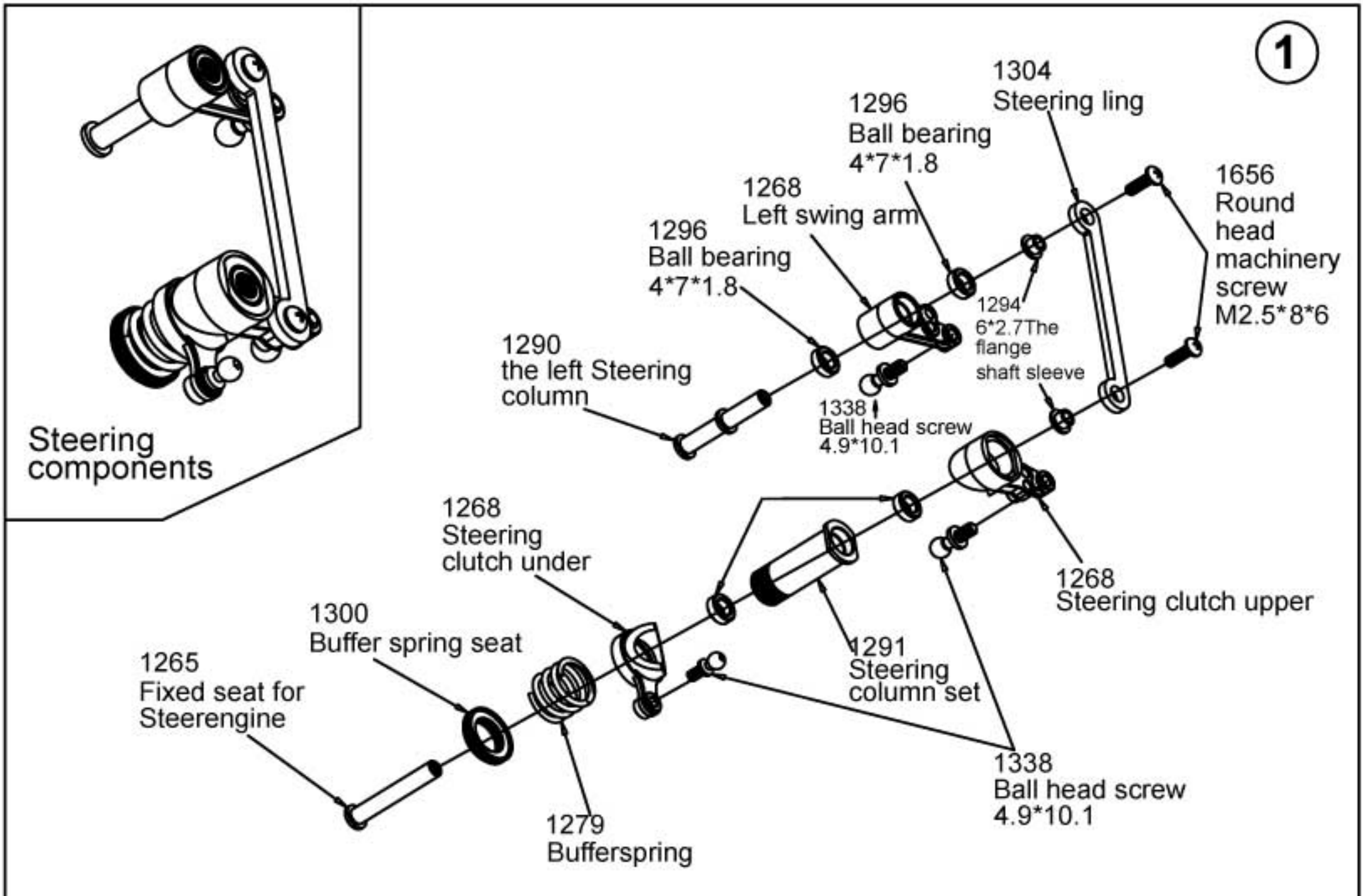

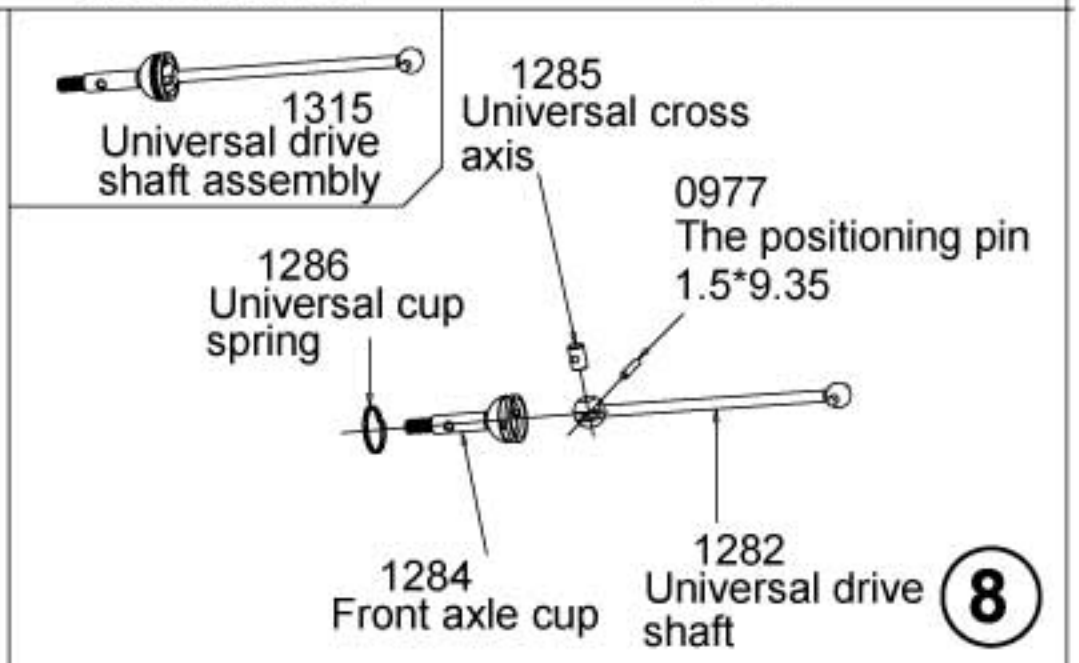
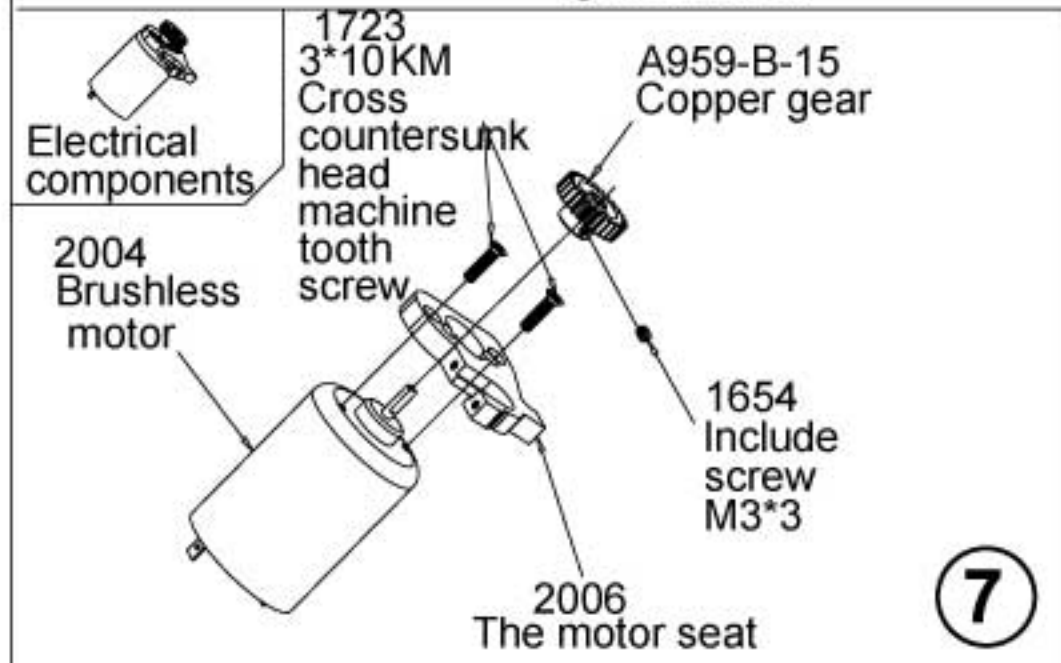
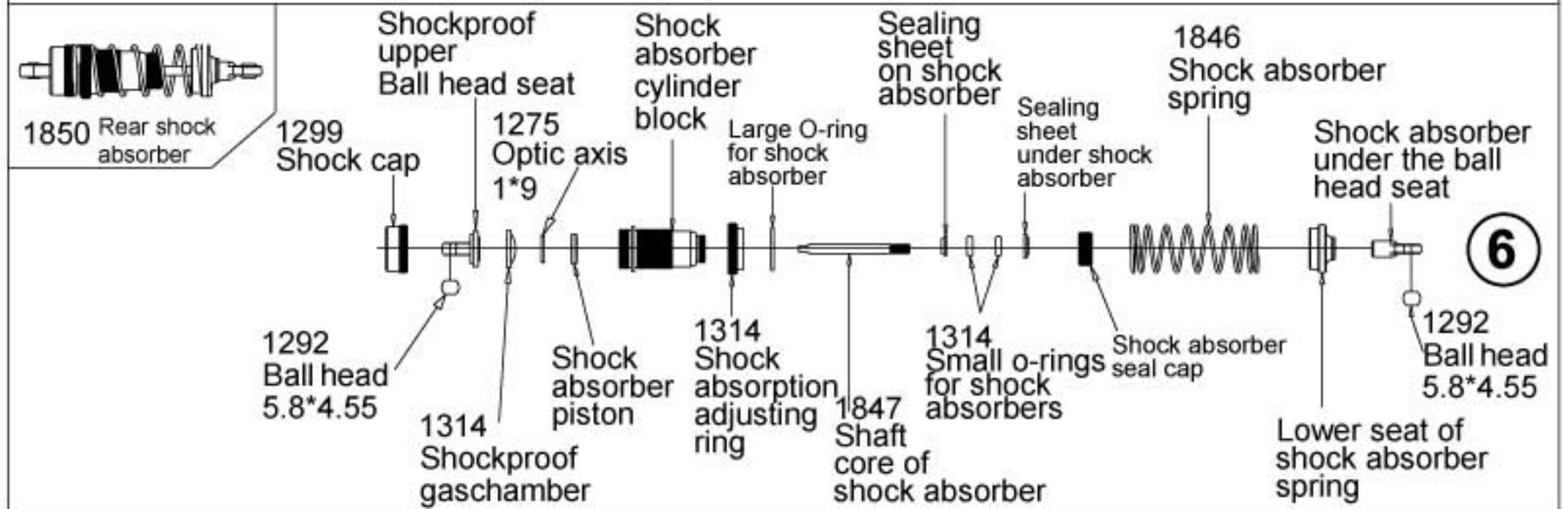
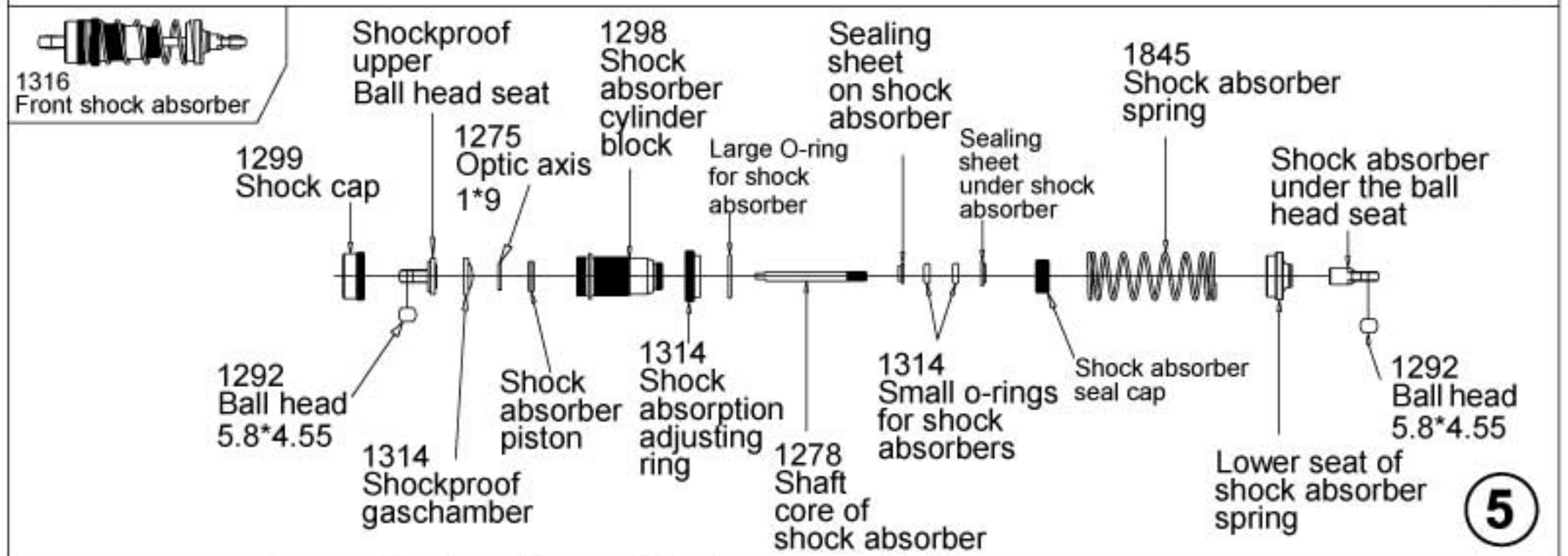
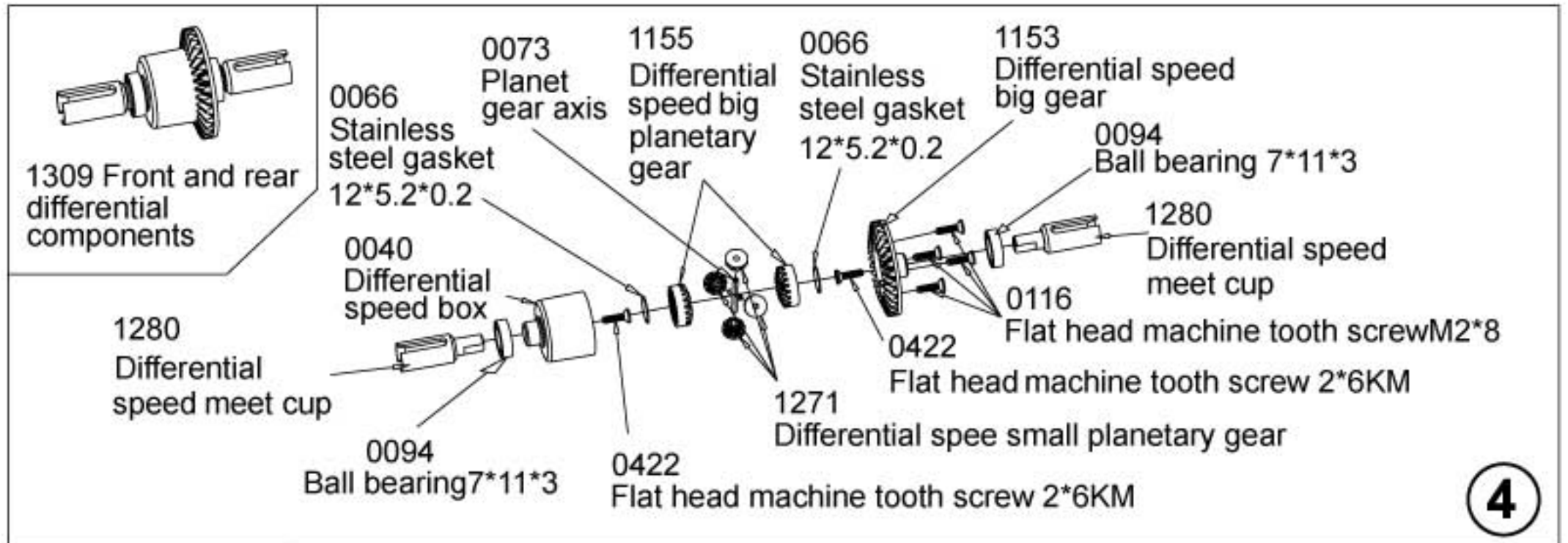

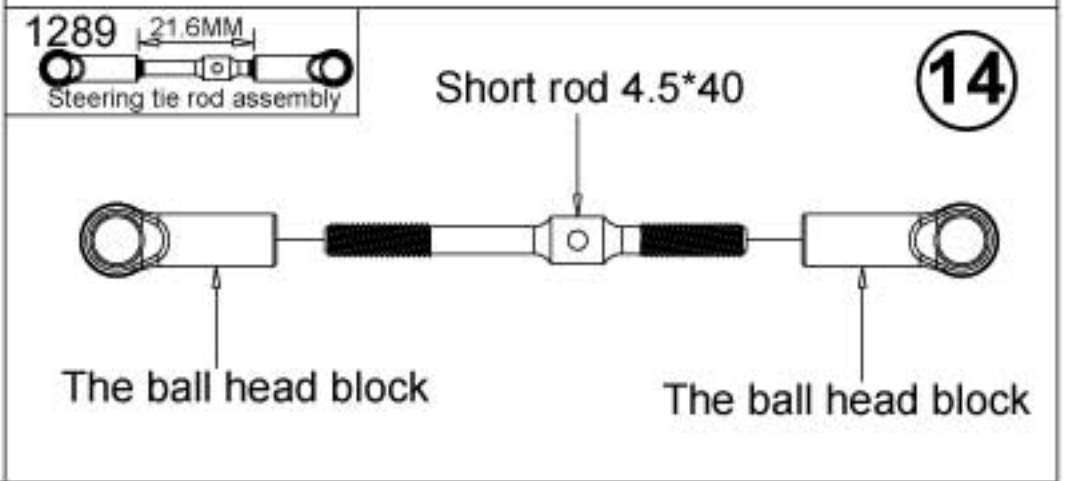
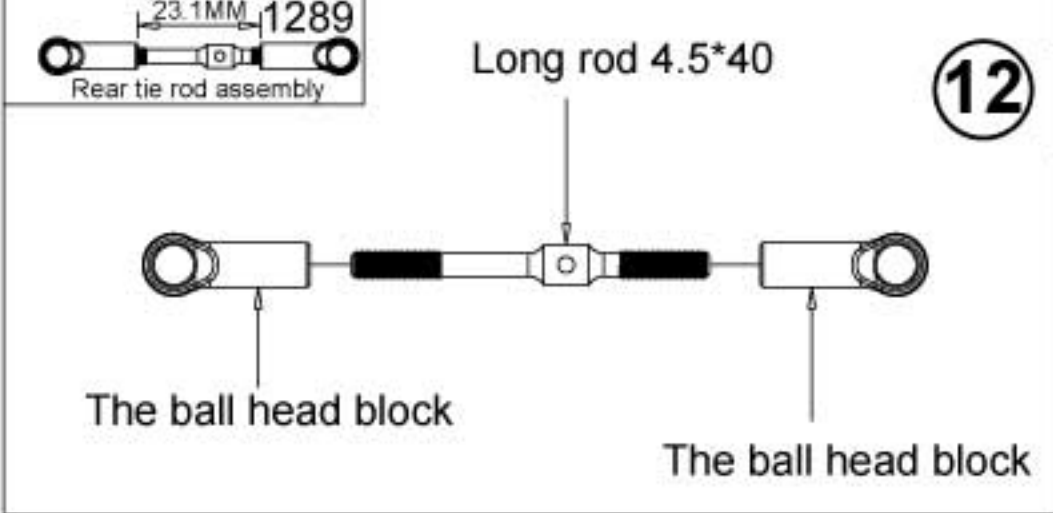
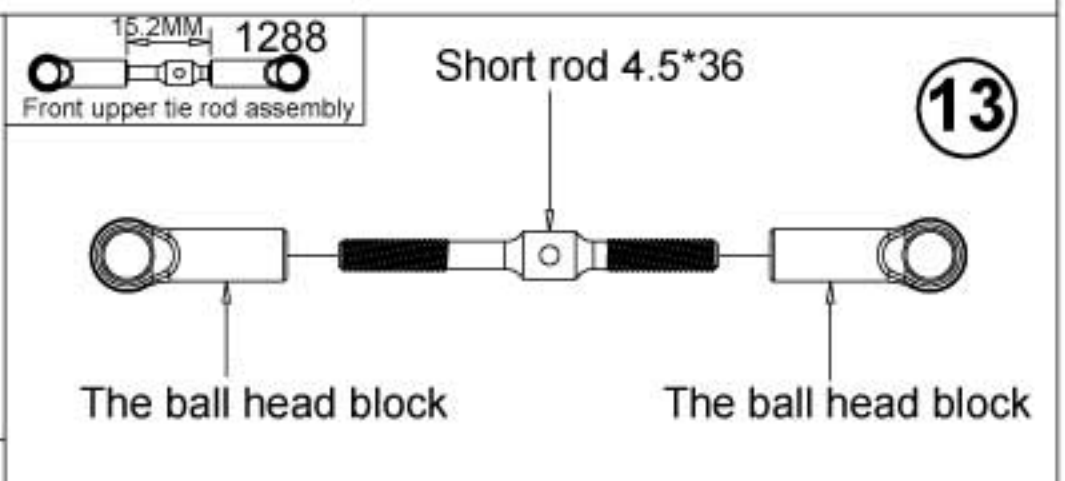
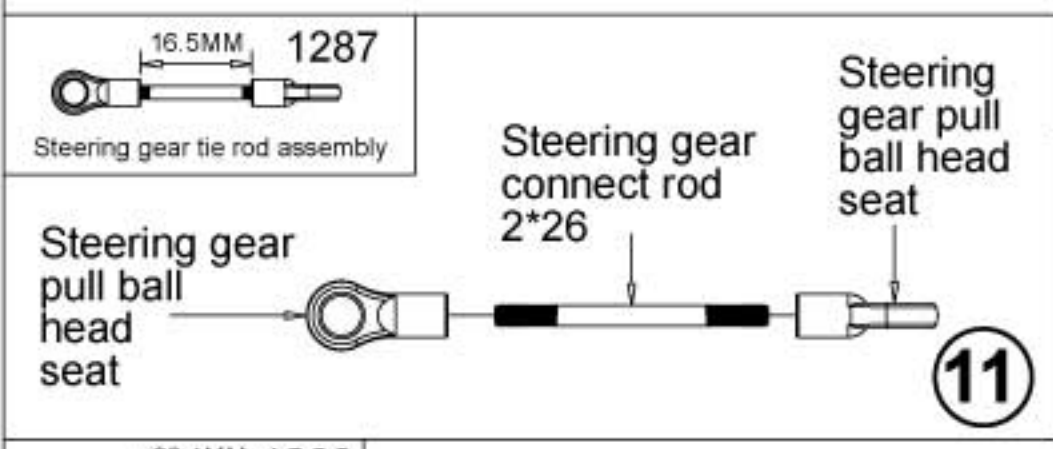
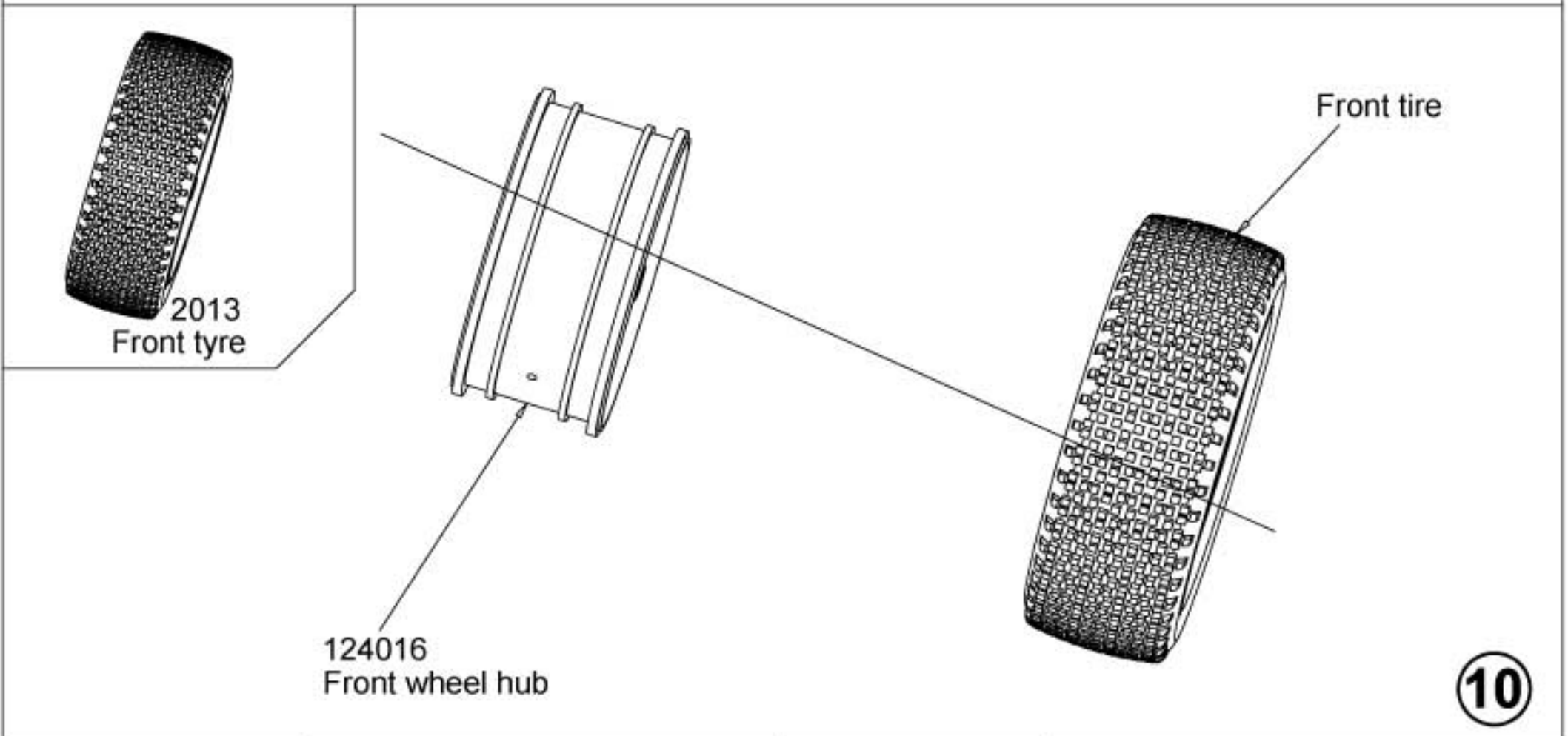
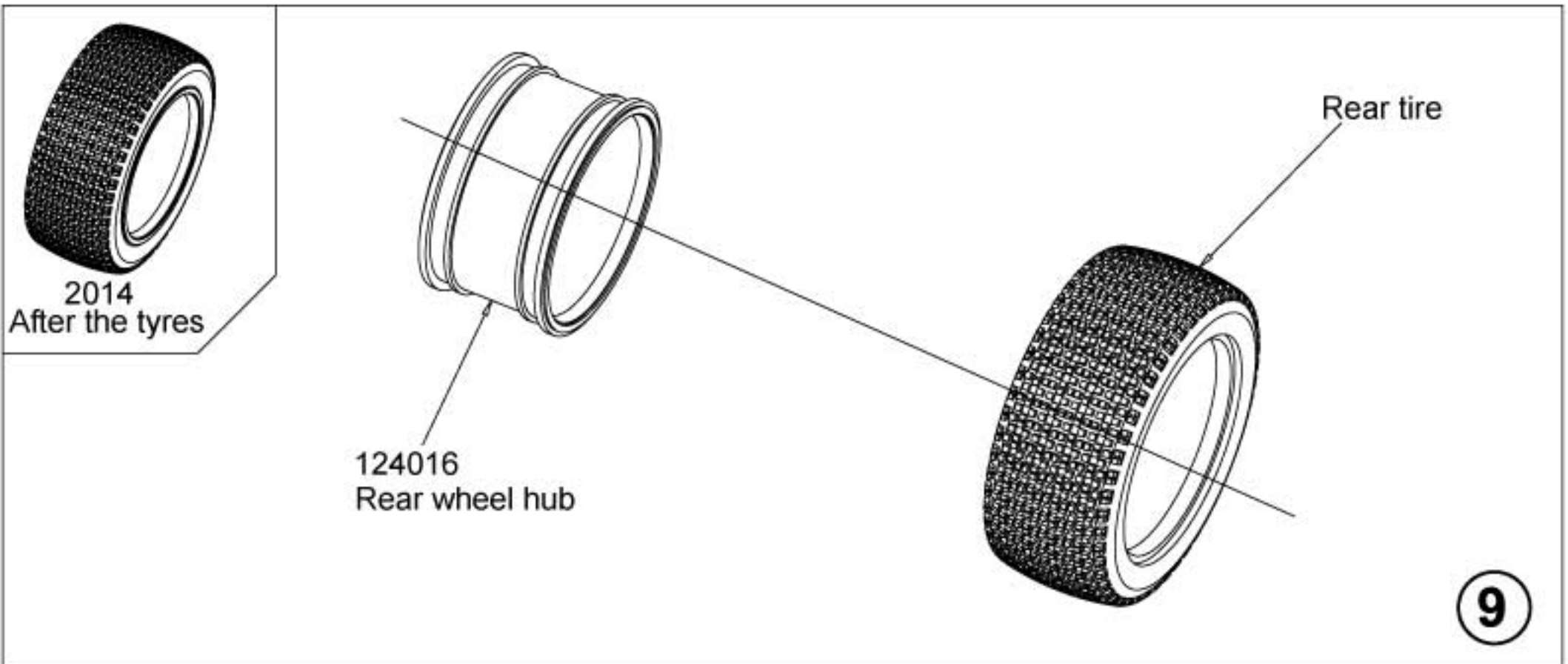

Central drive shaft assembly

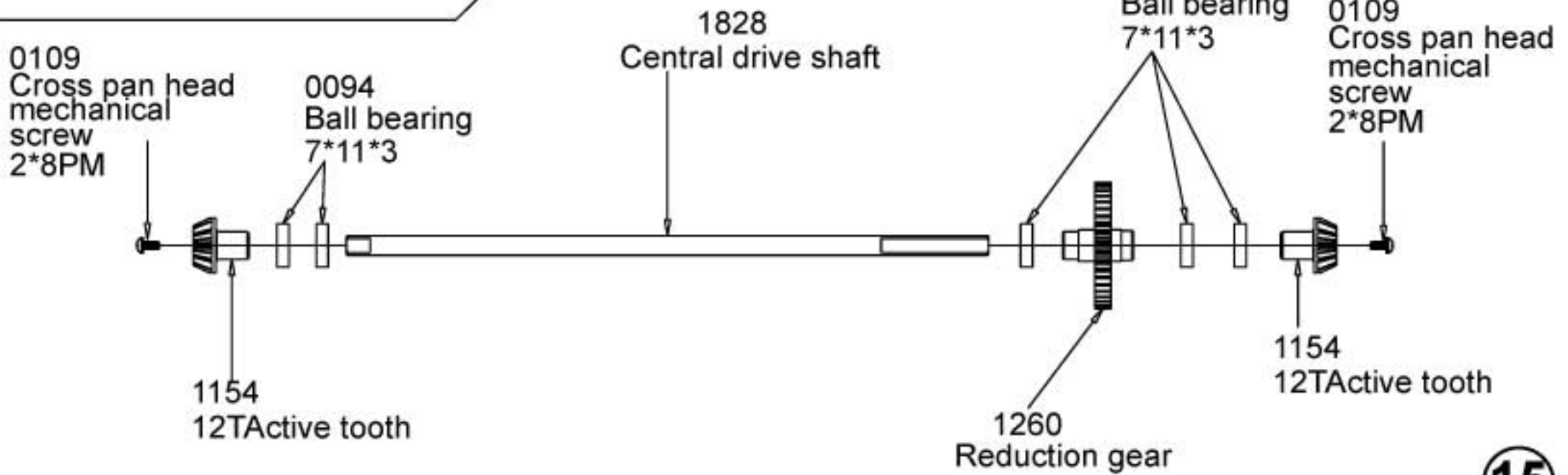

15

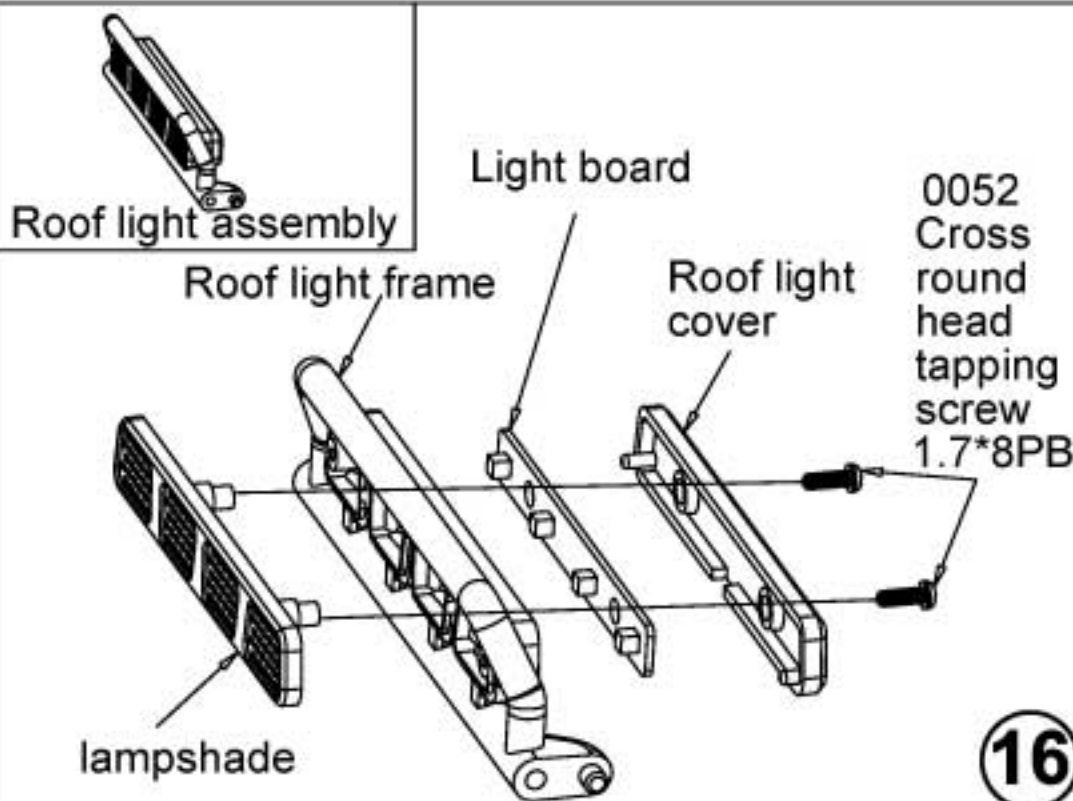

16

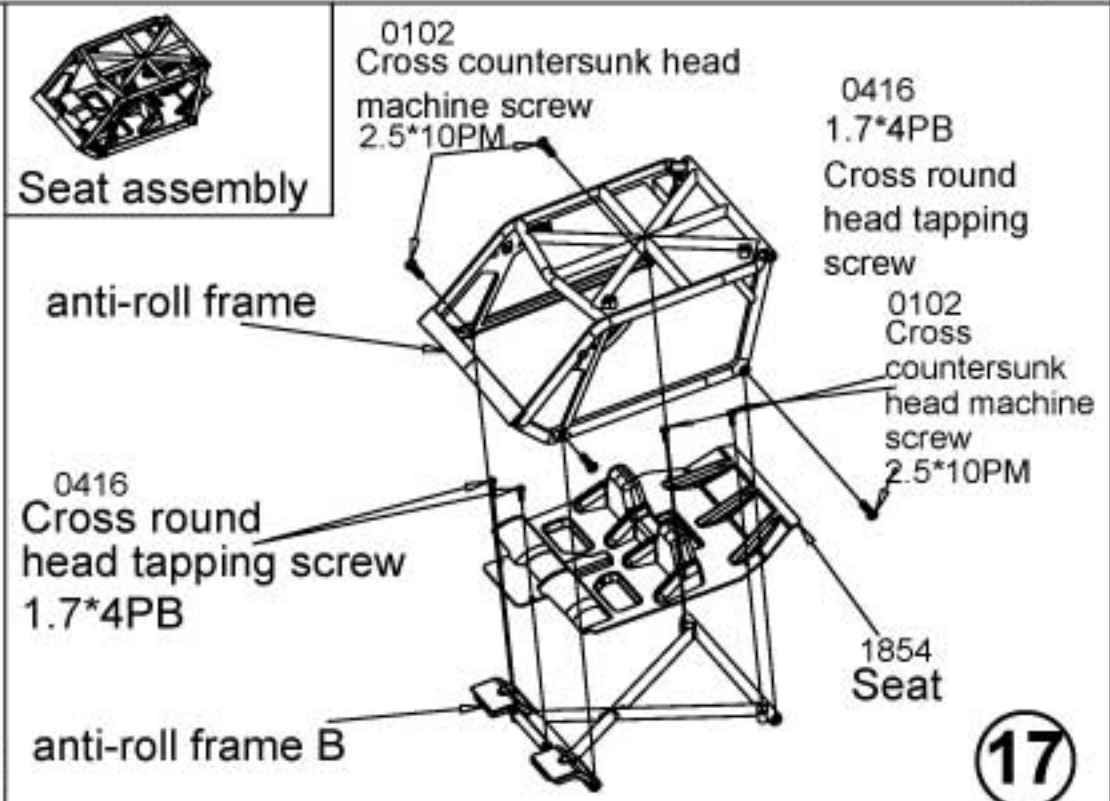

17

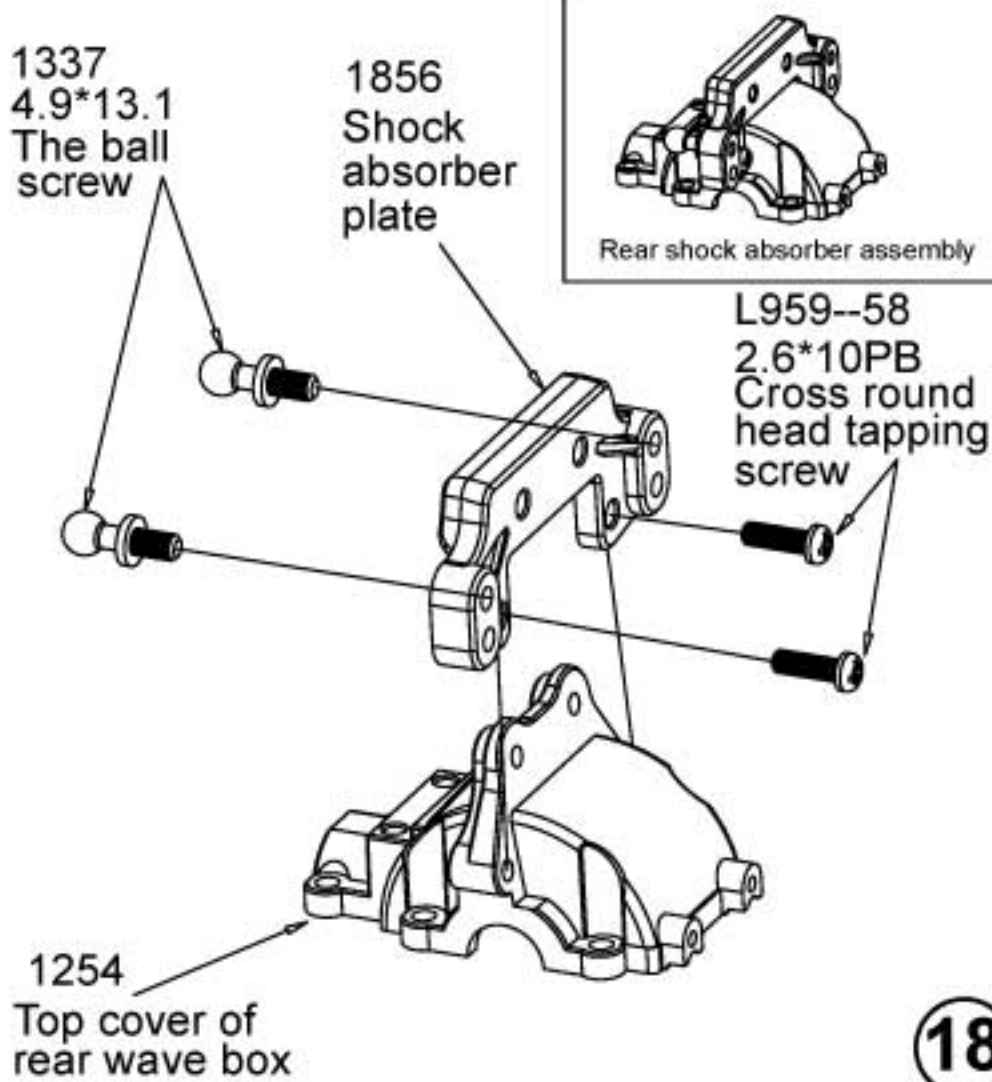

18

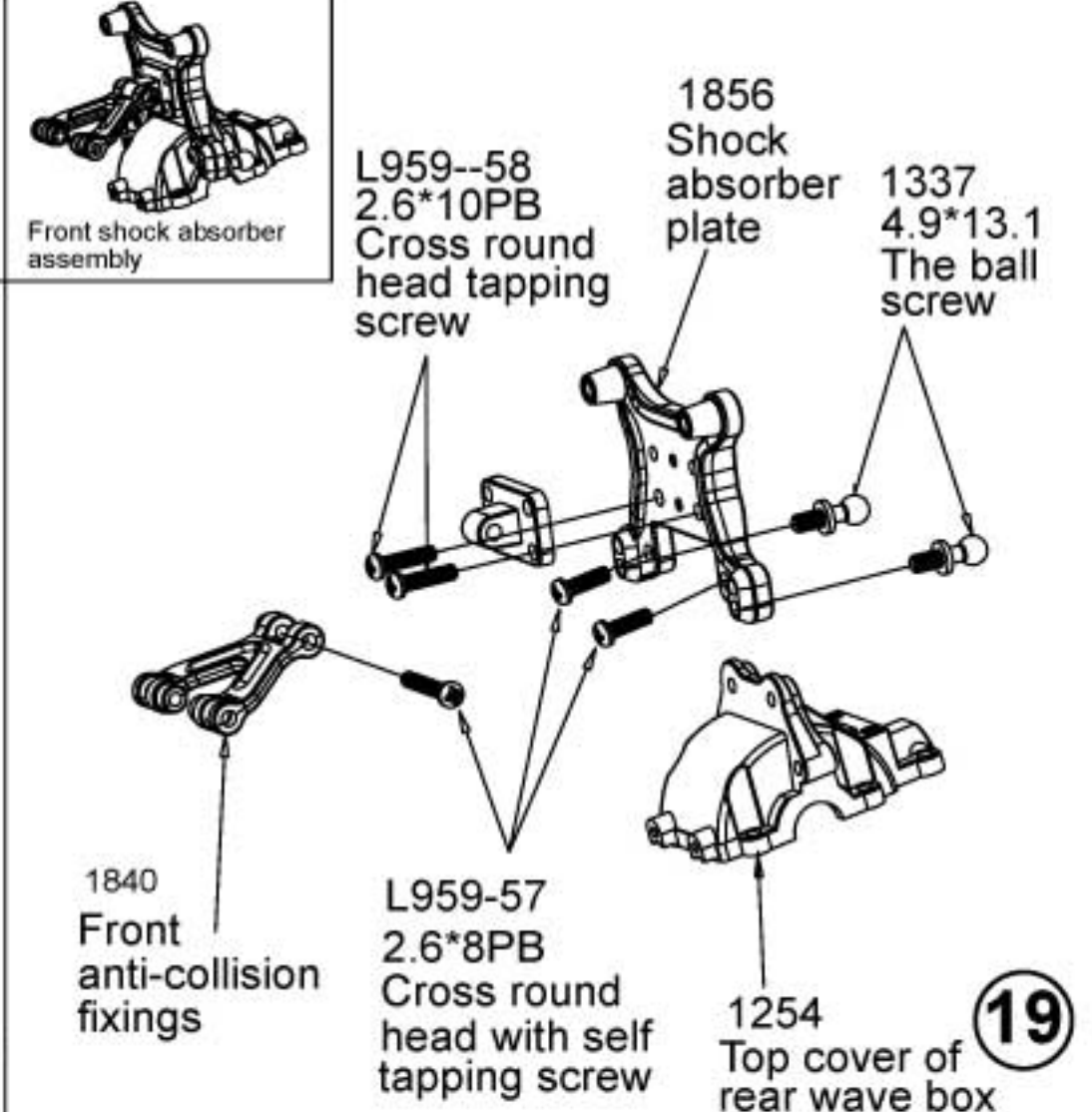

19

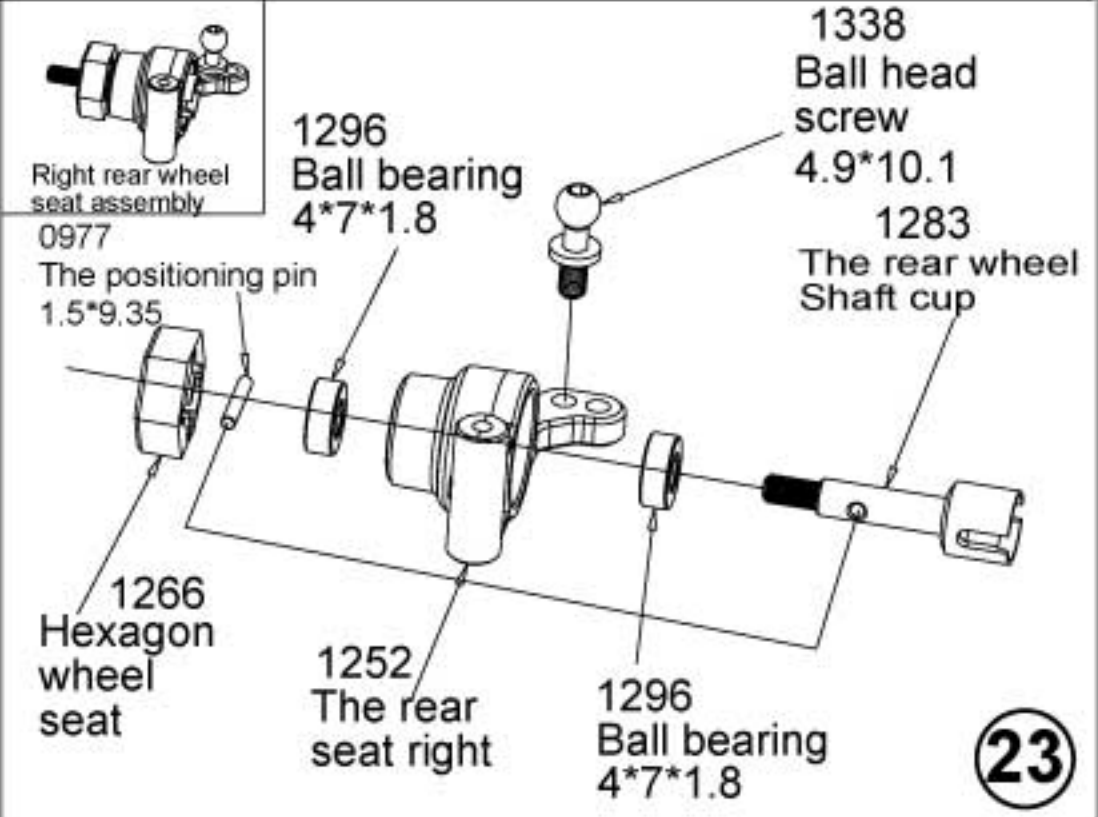
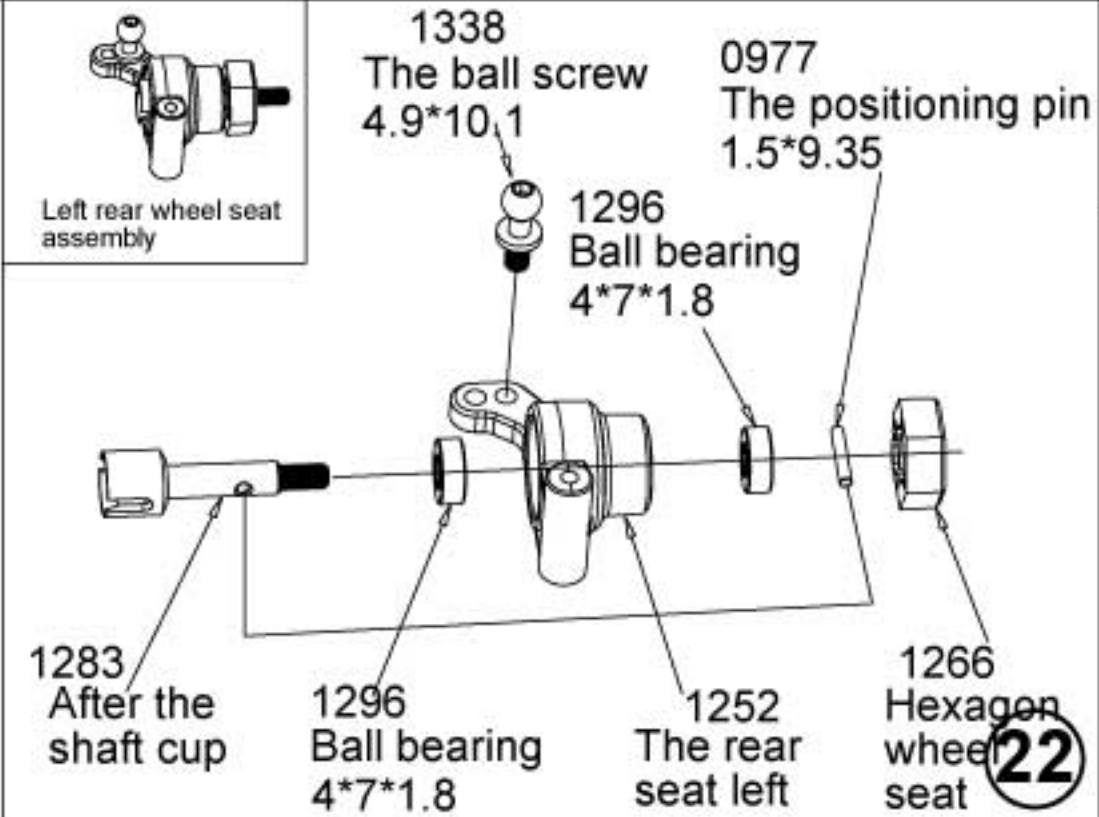
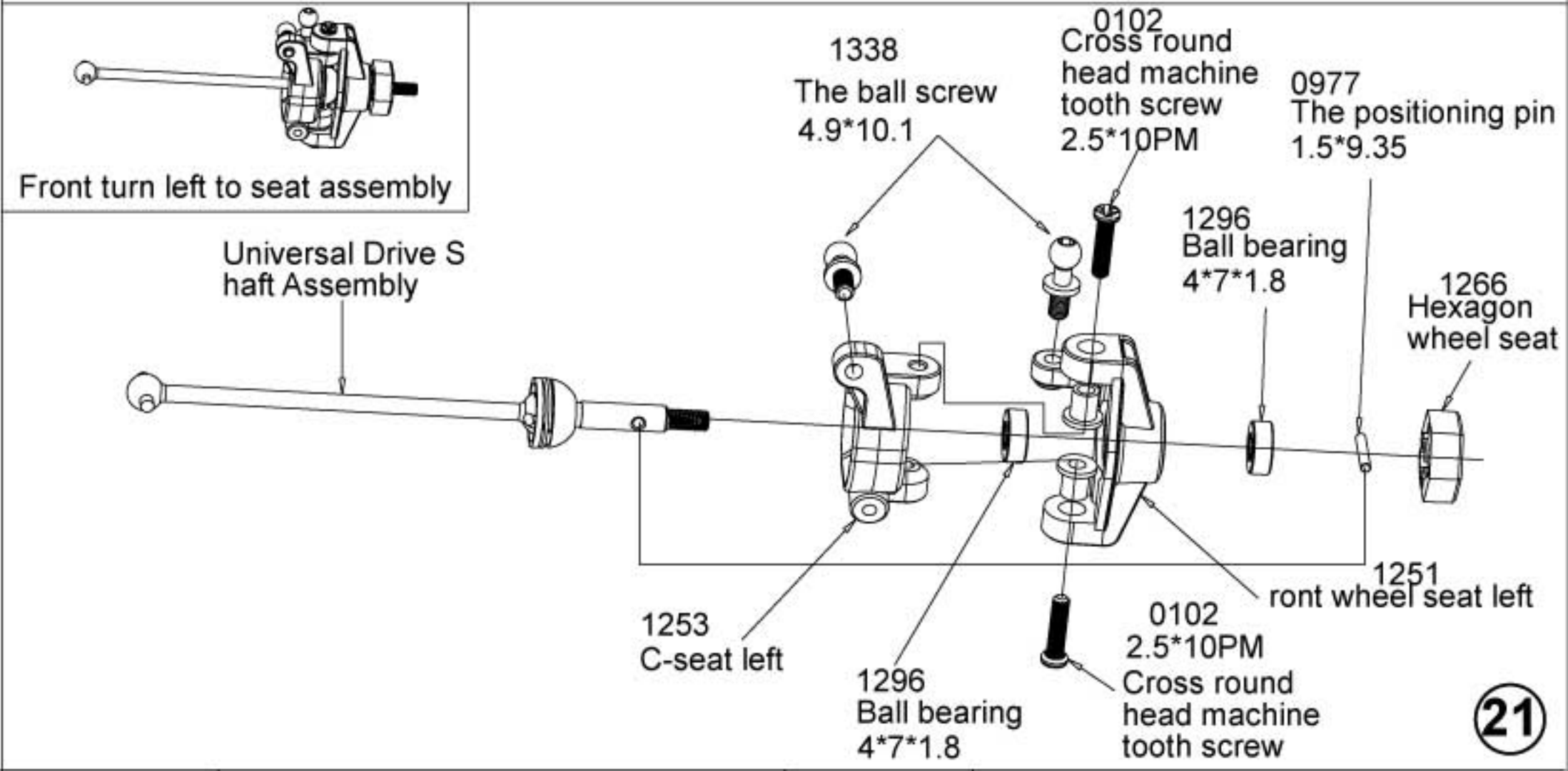
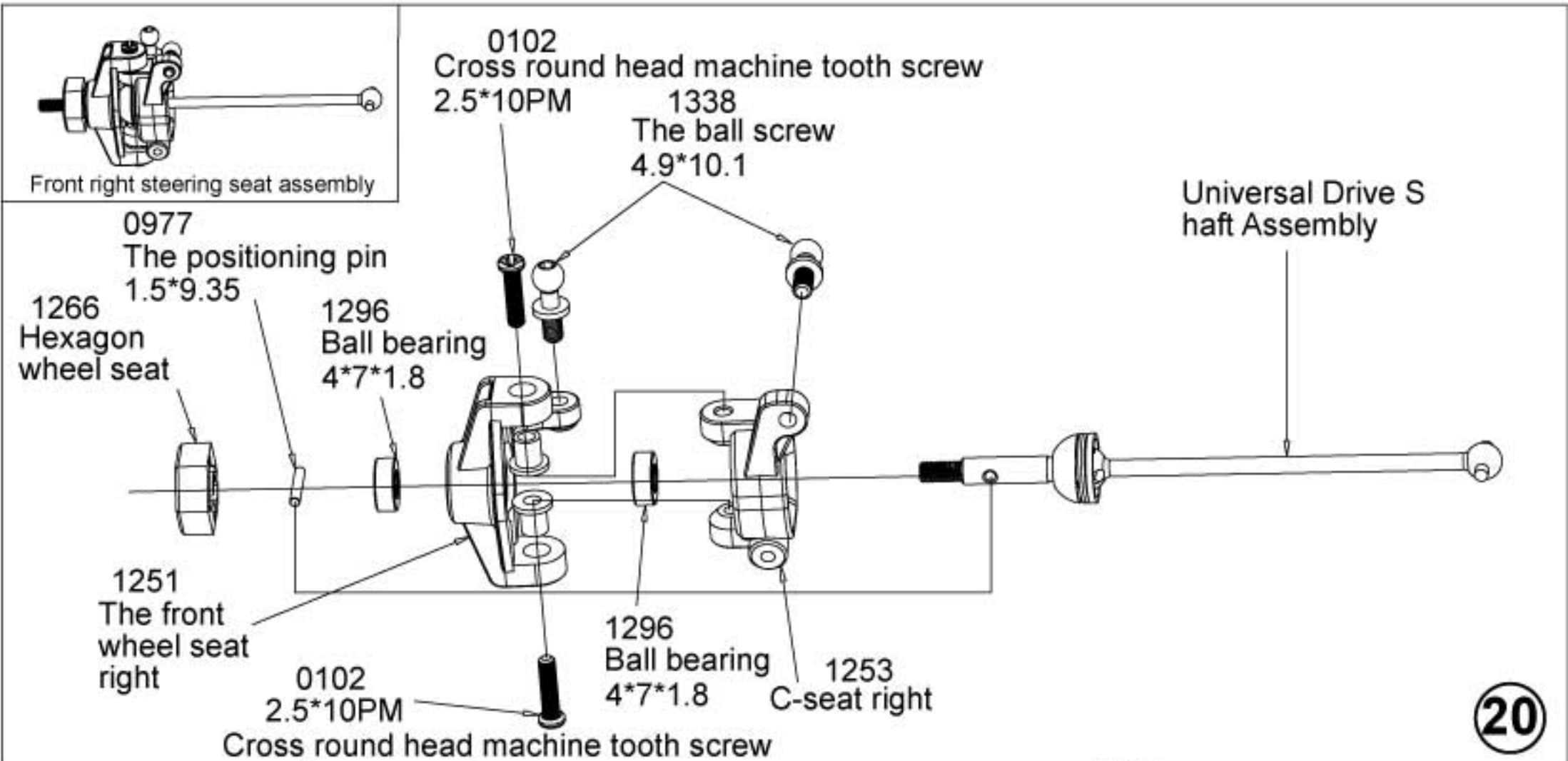

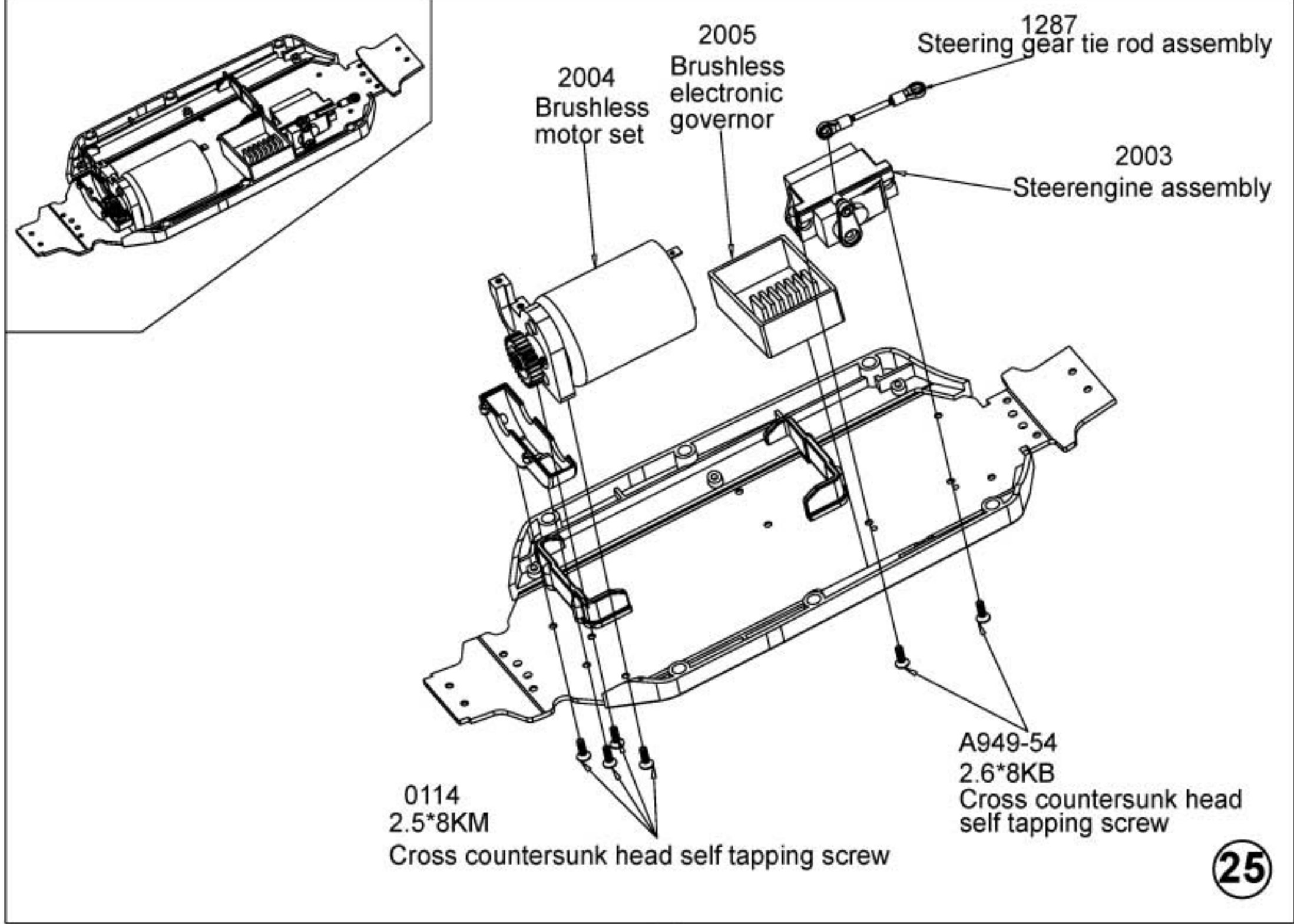
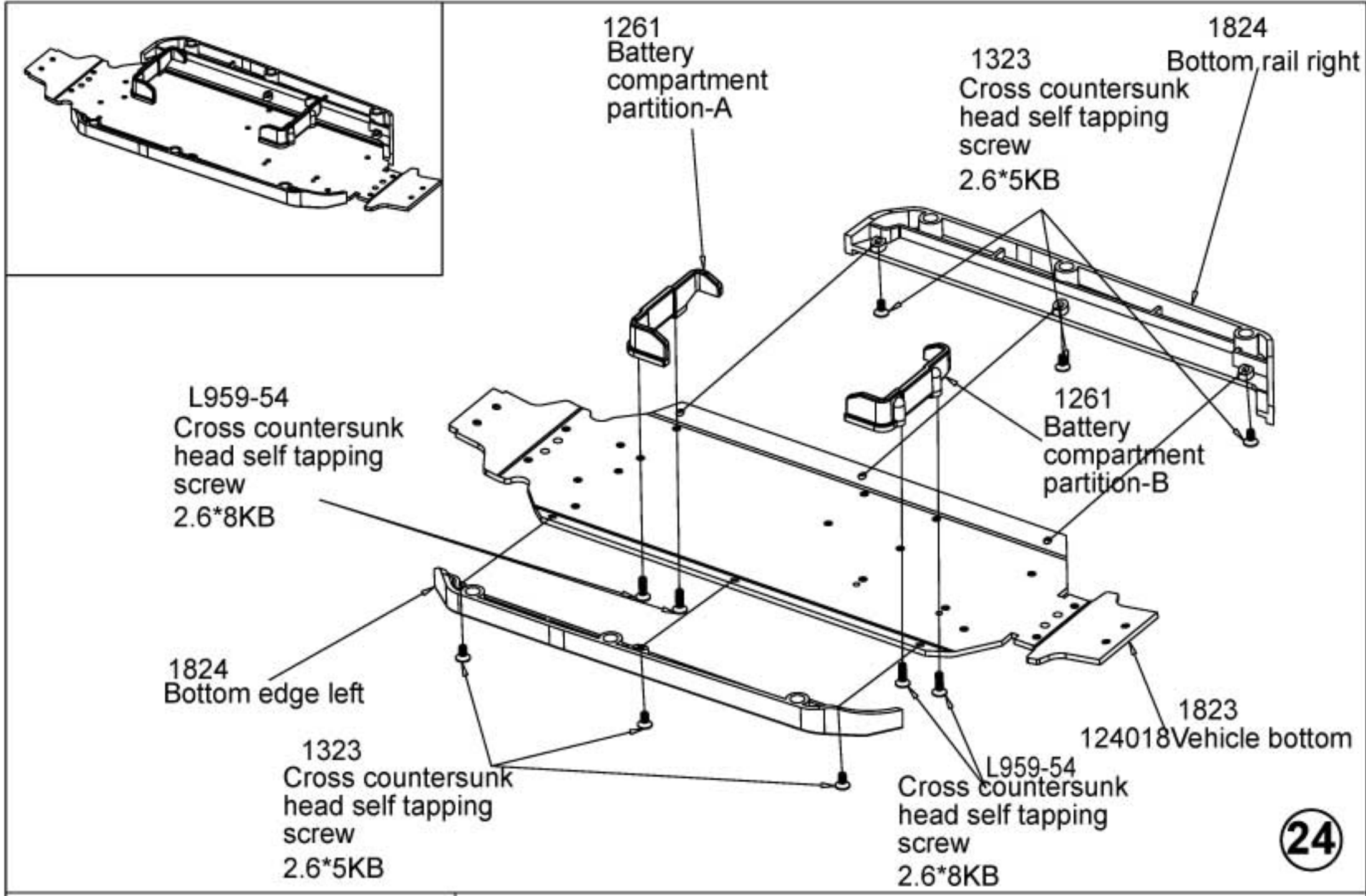

Rear wave box assembly

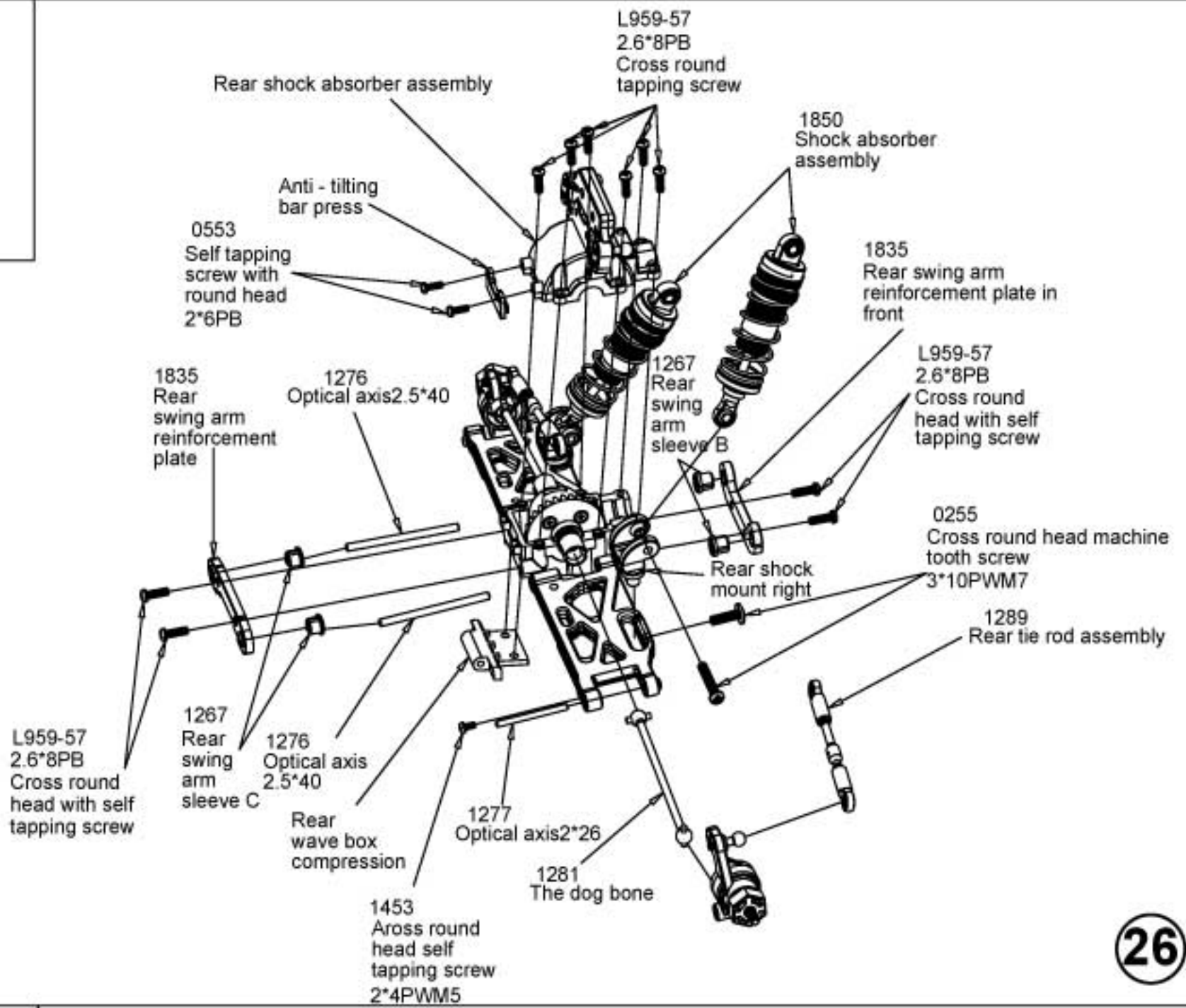

Front wave box assembly

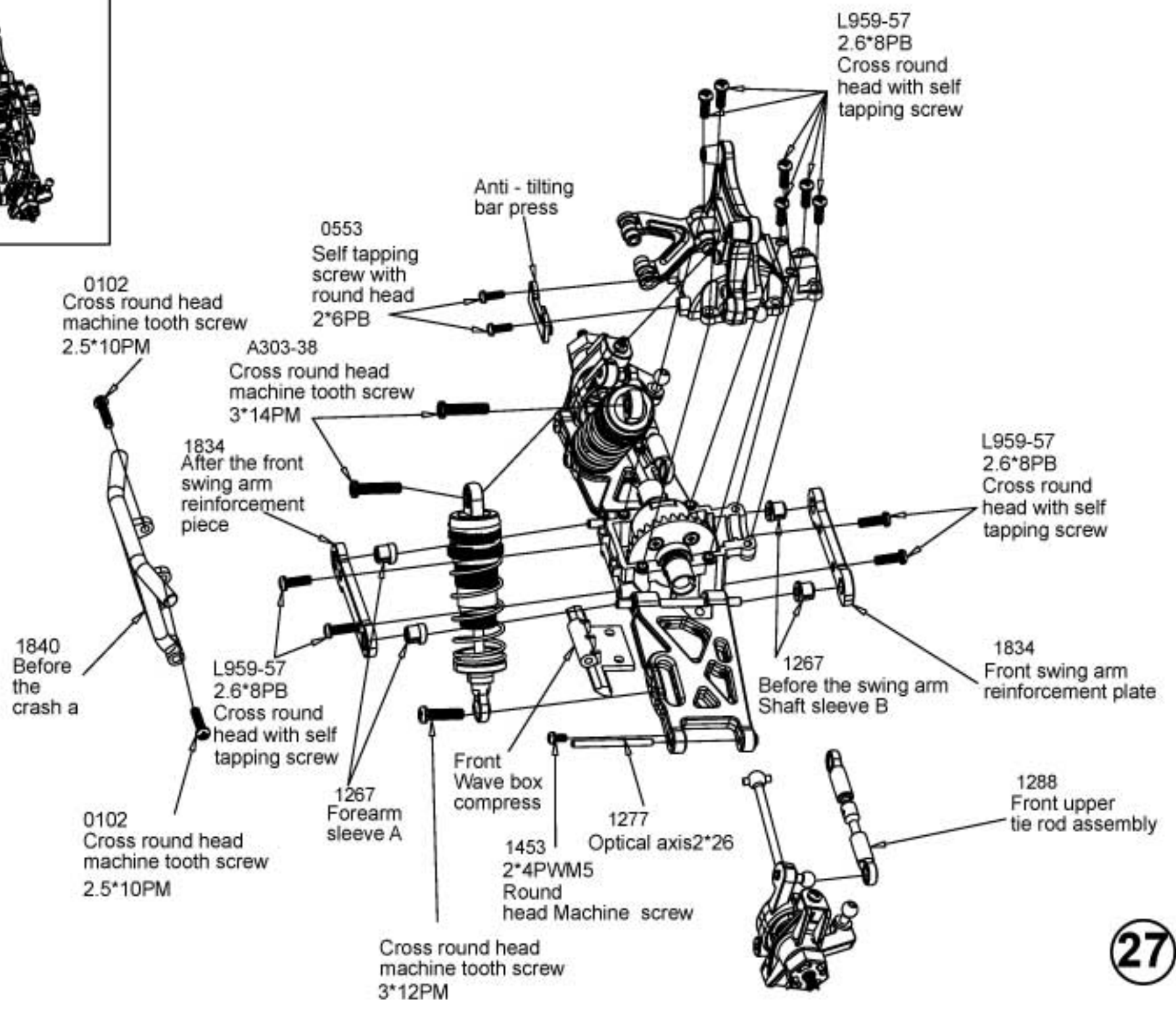

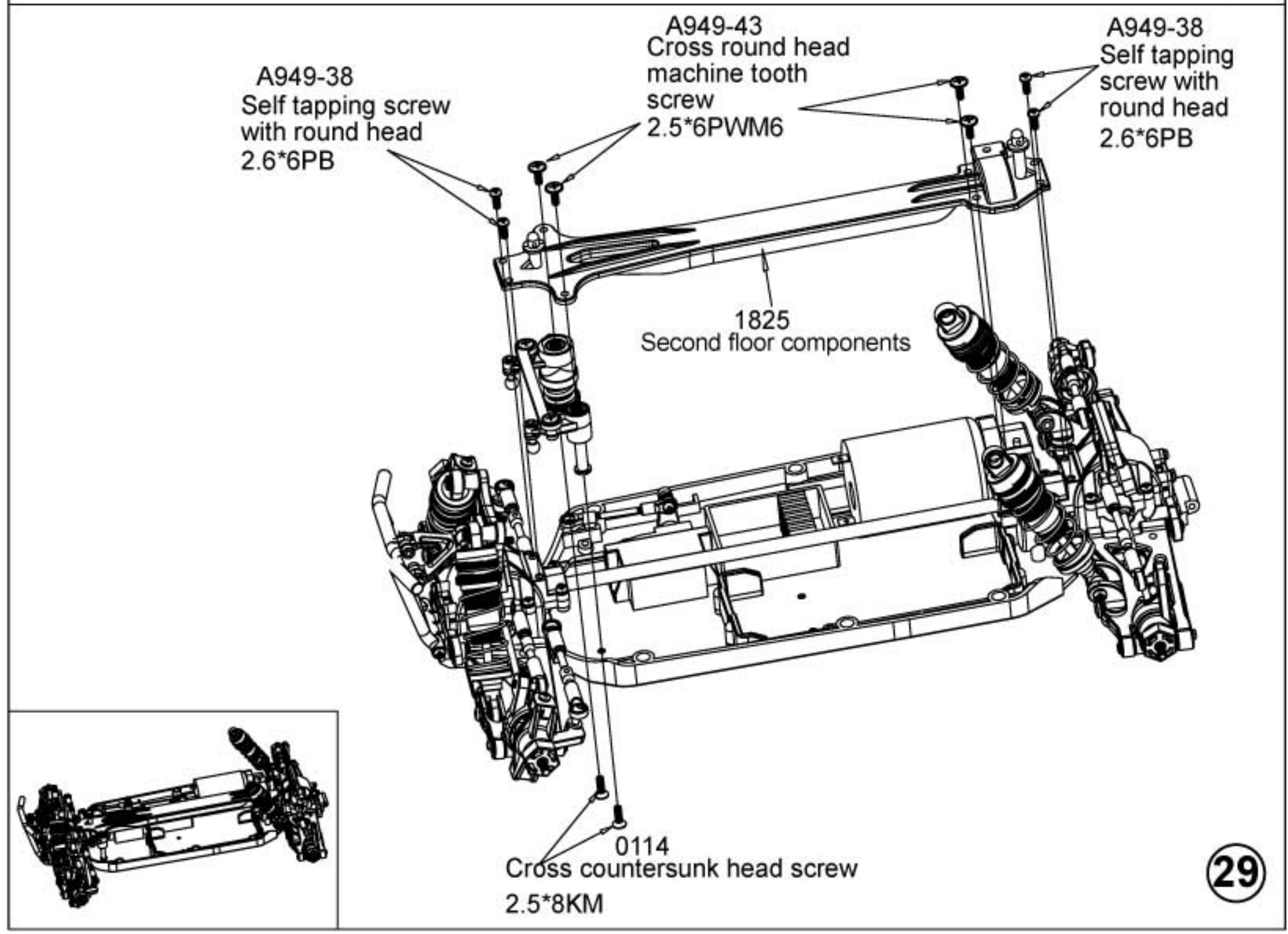
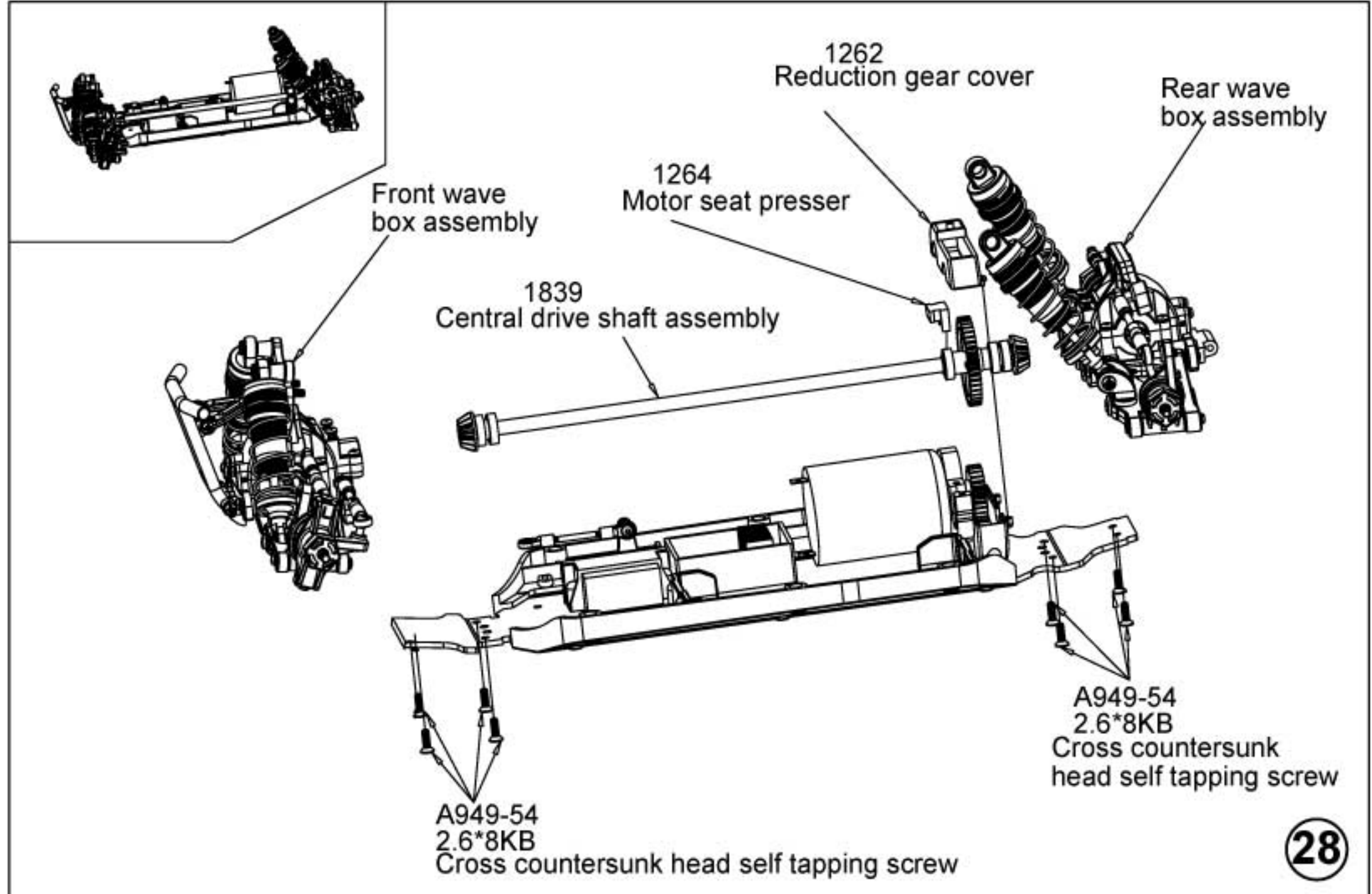

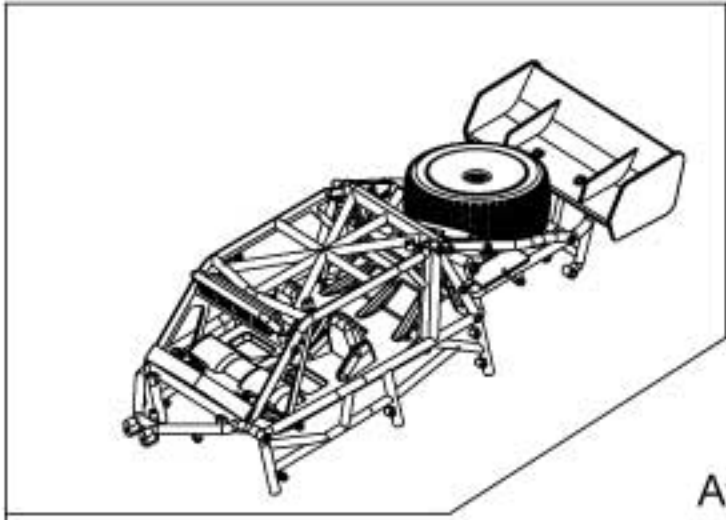

0105
Self tapping screw
with round head
2.5*16PM

0255
Cross round head
machine tooth screw
3*10PWM7

1857
The tail

30

2014
After the tyres

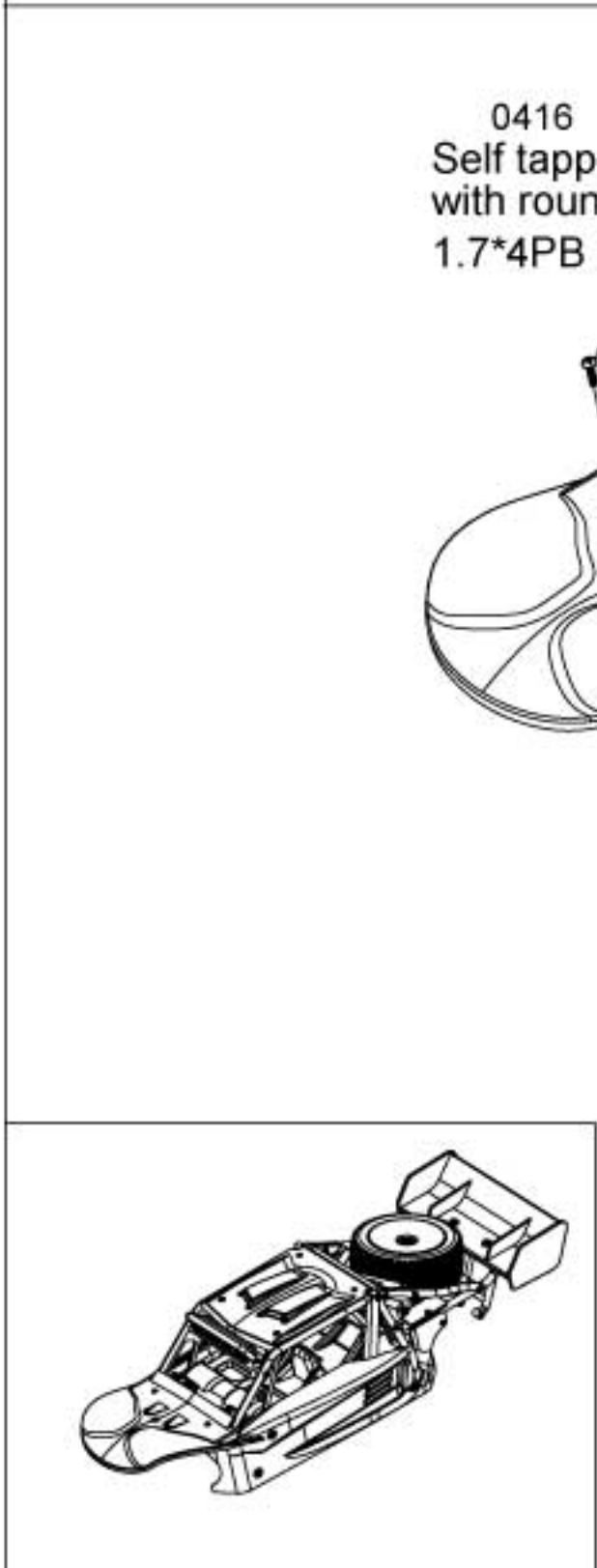
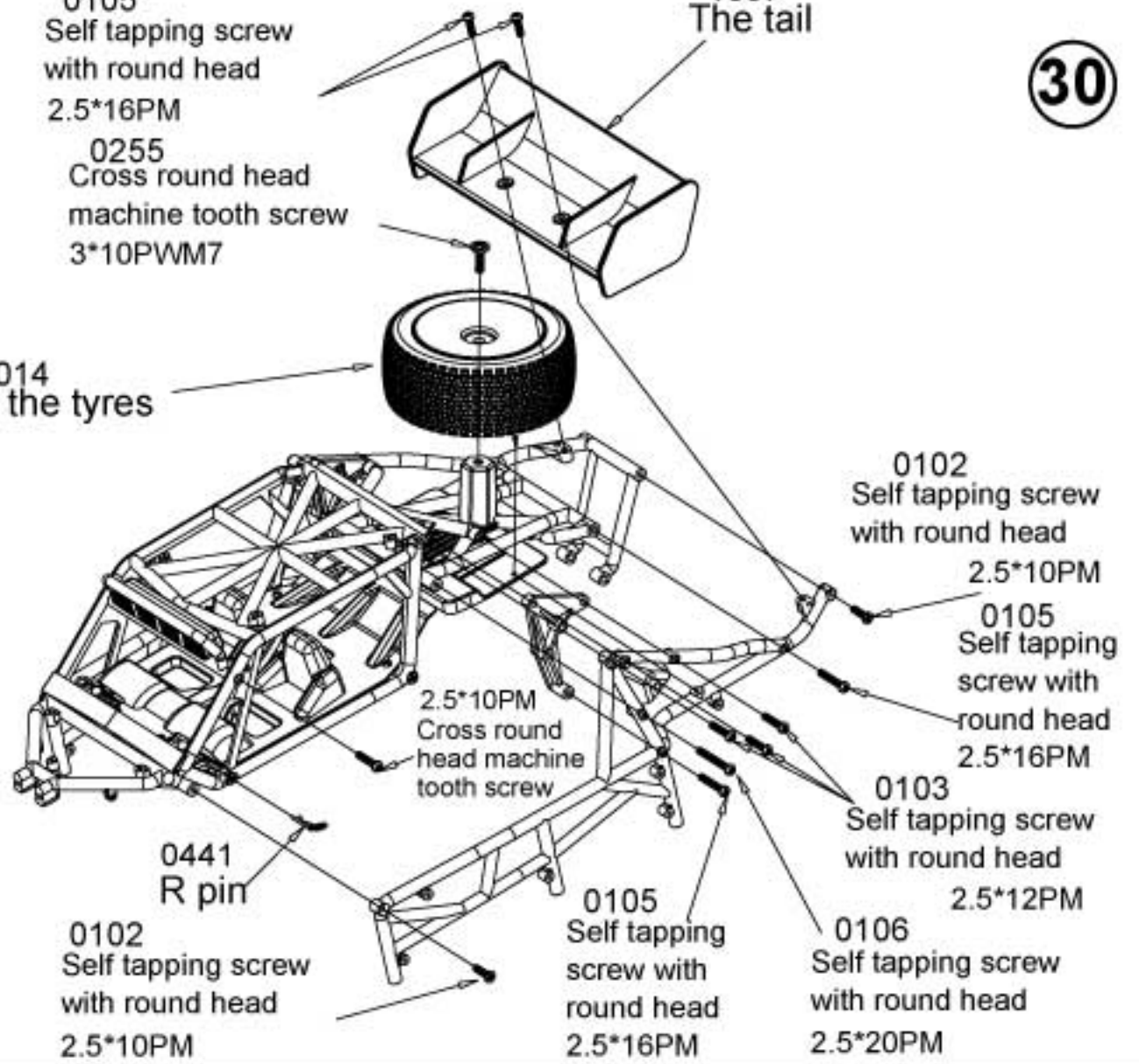

0416
Self tapping screw with round head
1.7*4PB

0416
Self tapping screw
with round head
1.7*4PB

31

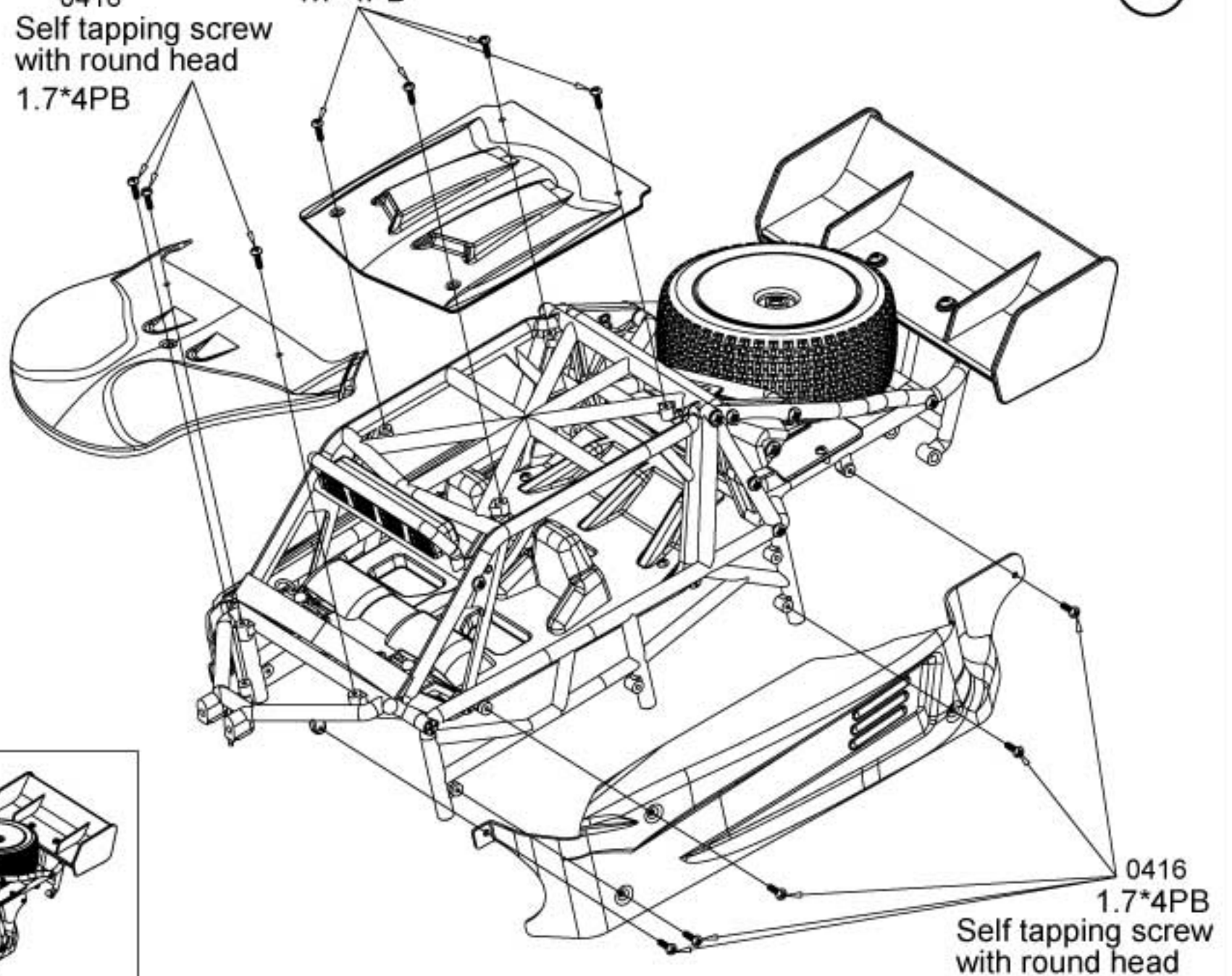



32

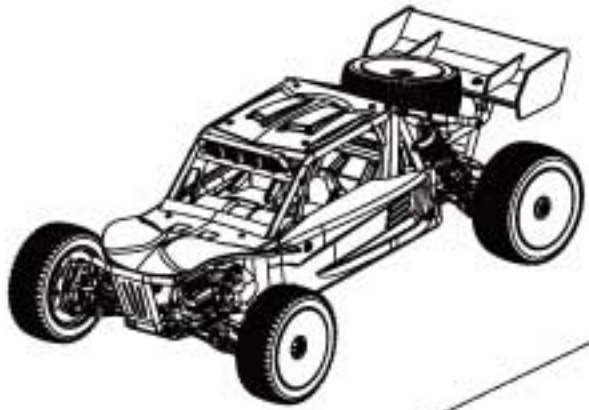
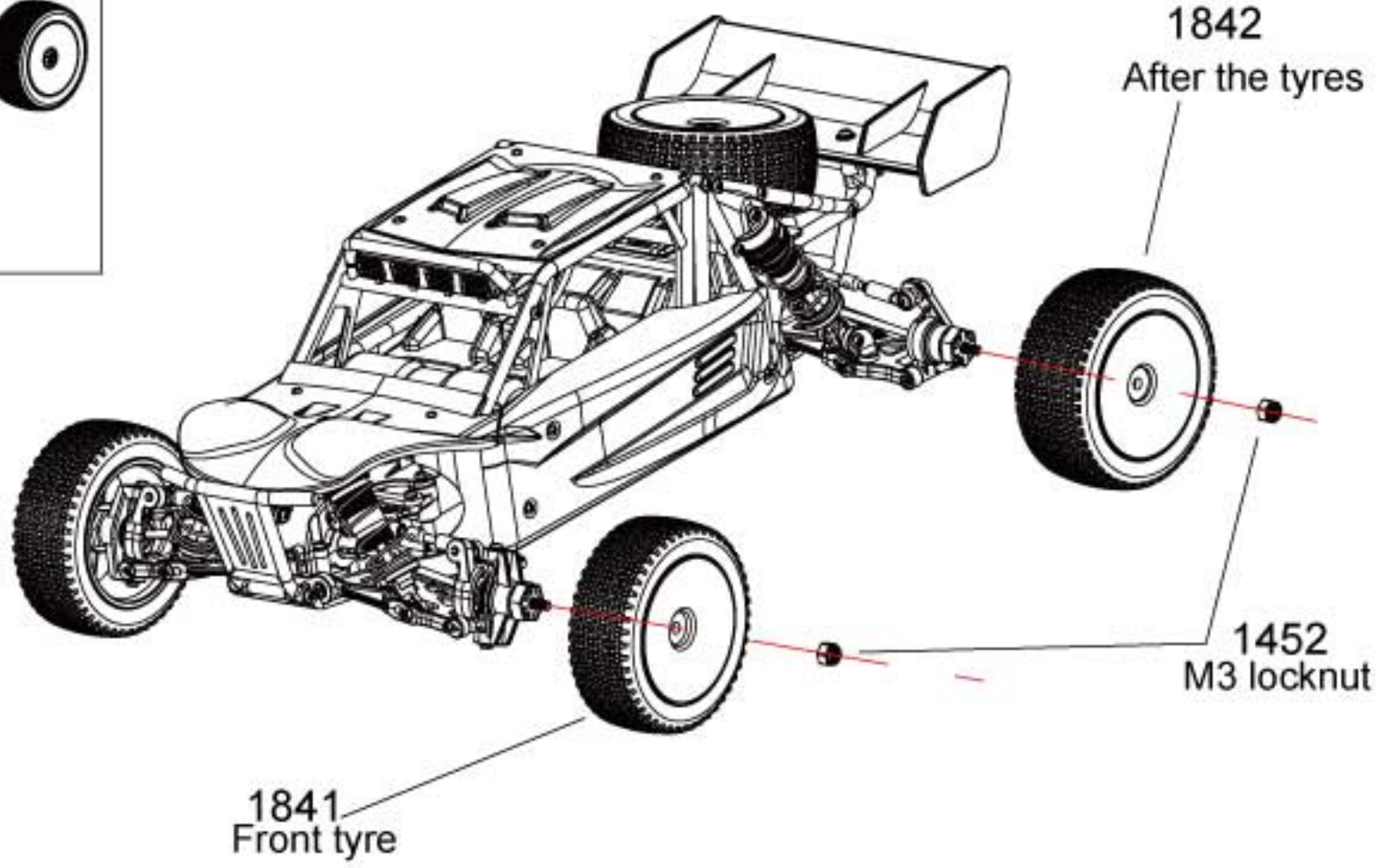

33

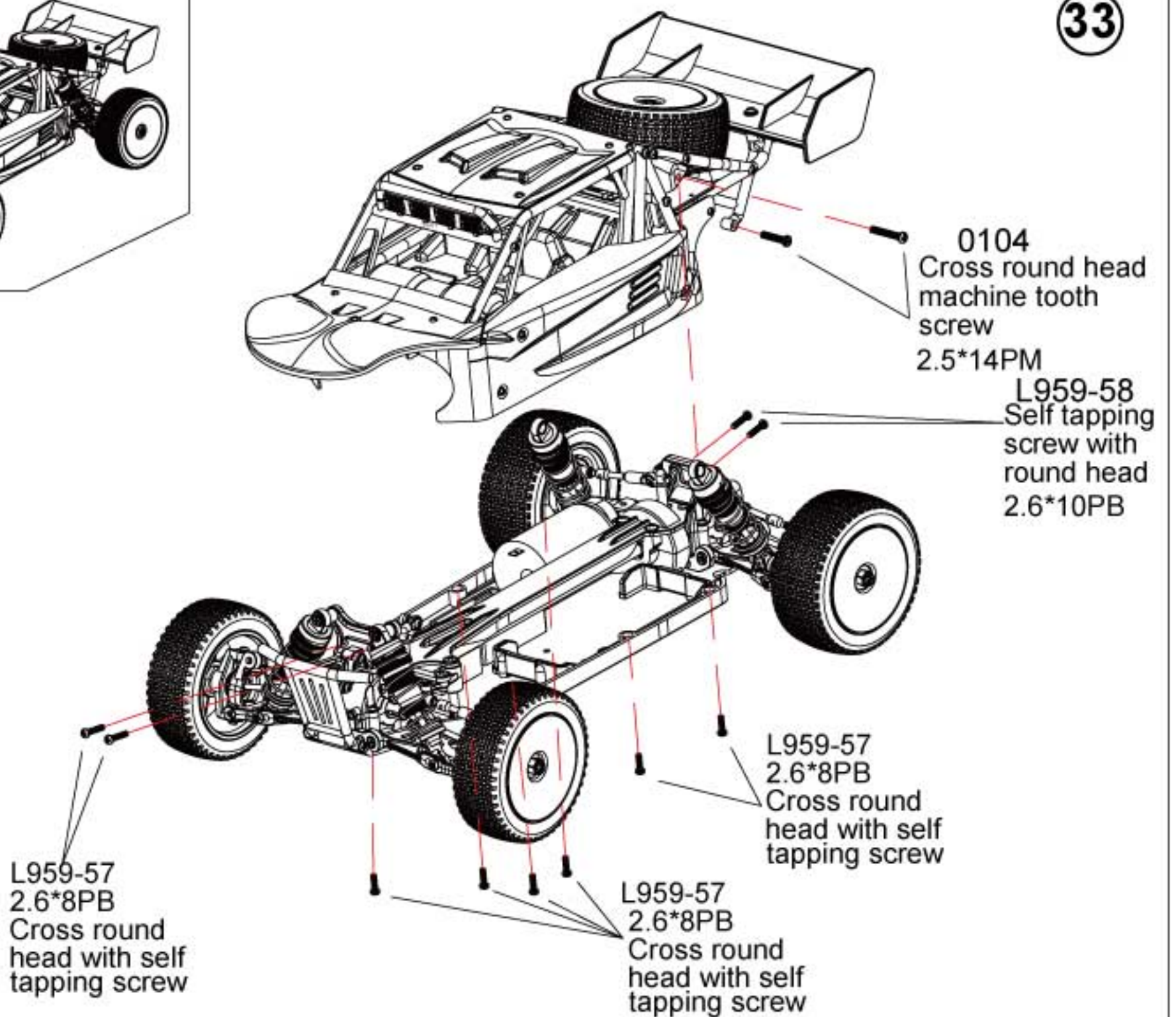

Sale parts view

0066



12 * 5.2 * 0.2 gasket set assembly

0073



Differential shaft assembly

0098

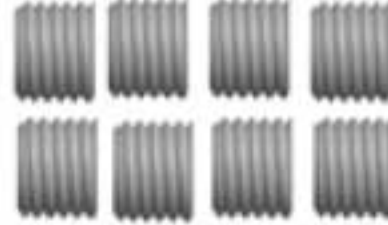

M3*3 Inner hexagonal screw assembly

0102

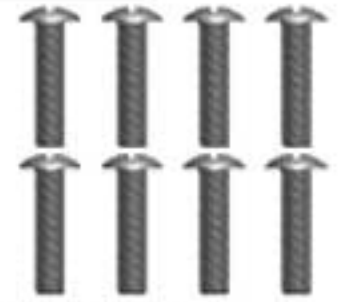

2.5*10PM screw assembly

0114



2.5*8KM screw assembly

0117



3*8KM screw assembly

1374



USB charging line

0256

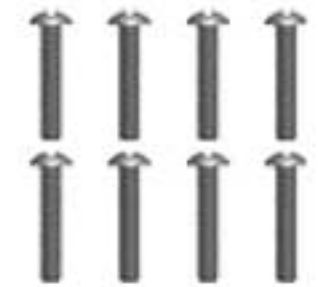

3*12PM screw assembly

1669



V2-144001 Remote controller

0422



2 * 6KM screw assembly

0553



2 * 6PB screw assembly

0582



ST2*7PB screw assembly

1153



30T Differential Large Teeth(Hardware) Component

1154



12T Active Teeth(Hardware) Group

1155

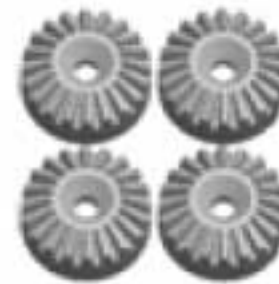

24T Differential Large Planetary Teeth(Hardware) Group

1823



car body assembly

1250



Front and rear arms

1251



Front seat assembly

1252



Rear seat assembly

1253



Type C Block Component

Sale parts view

1254



Wave Box Component

1824



Bottom side guard assembly

1256



Ball head support assembly

1857



Tail group

1840



Front and rear collision avoidance group

1825



Second floor panel components

1260



Slow down large tooth assembly

1261



Battery partition assembly

1262



Speed gear upper and lower cover assembly

1263



Tiller arm assembly

1264



Motor seat press component

1265



Steering seat press assembly

1266



Hexagonal seat assembly

1267



Front and rear arm sleeve

1268



Switch to clutch component

2013

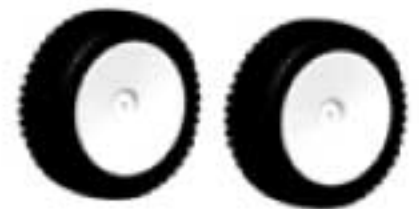

Front tire assembly

2014

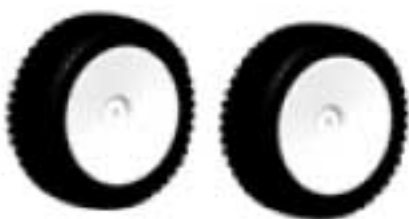

Back tire assembly

1271

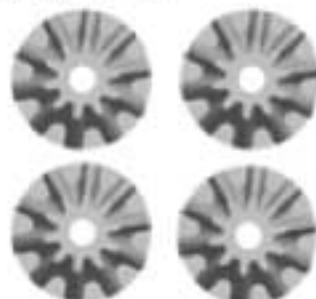

10T Differential Asteroid Teeth(Hardware) Group

1845

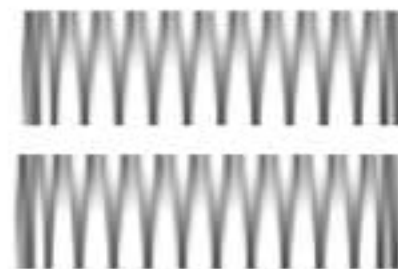

Front shock spring set

1274

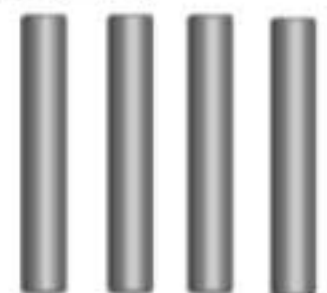

1.5*9.35 Optical axis

Sale parts view

1275



1*9 Optical axis

1276

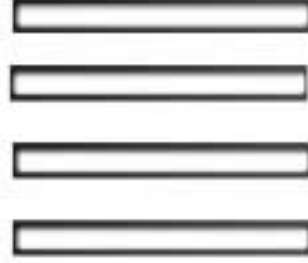

2.5*40 Optical axis

1277



2*26 Optical axis

1278



Shock absorber shaft component

1279



Buffer spring assembly

1281



Dog bone assembly

1282



Universal drive shaft assembly

1283



Rear Wheel Cup Component

1284

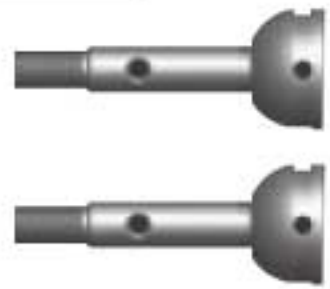

Front Wheel Cup Component

1285

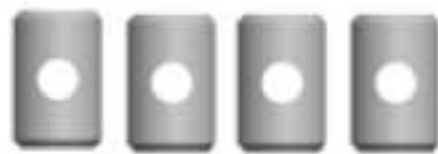

Cross shaft assembly

1286



Universal cup spring assembly

1287



Steering gear lever assembly

1288



Short pull bar assembly

1289



Long pull bar assembly

1290



Steering column assembly

1291



Steering column sleeve component

1292

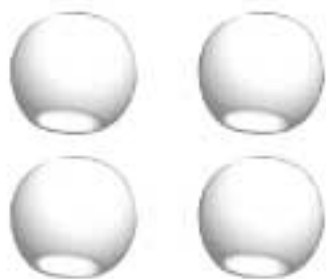

Ball Head Component

1828



Central Transmission Axis Component

1294



6 * 2.7 flange sleeve assembly

1295



6 * 5.2 flange sleeve assembly

Sale parts view

1296



Ball bearing assembly

1298



Shock absorber cylinder assembly

1299



Shock absorber cap assembly

1300



Regulate Ring Component

1301



Spring seat assembly

1844



Left and right groups of lower fixed base of rear shock absorber

2006



Motor Block Component

1304



Steering connecting rod assembly

1834



Front swing arm reinforcement module

1835



Backswing arm reinforcement module

2003



Rudder assembly

2004



Motor components

1309



Differential

2005



Receiver board assembly

1314

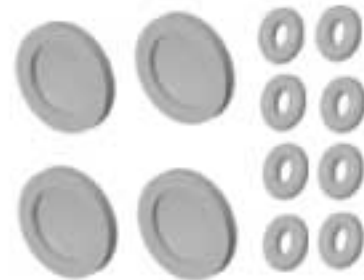

Type 0 assembly

1315



Coaxial component

1849



Front shock mount

1323



ST2.6*5KB screw assembly

2007



Car shell components

1336

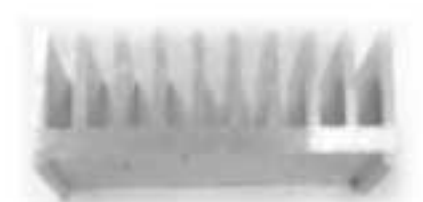

Heat Discharge Group

Sale parts view

1337



4.9*13.6 Ball Head screw assembly

1338



4.9*10.6 Ball Head screw assembly

A202-04



4.0*9.5 Ball Head screw assembly

A202-15



ST2*8KB screw assembly

A303-39



ST2.6*6PWB6 screw assembly

1654

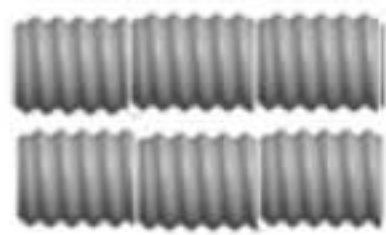

3 * 3 Hexagon socket screw

1651



Magic paste group

A949-35



Ball bearings 7 * 11 * 3 groups

A949-38



ST2.6*6PB screw assembly

A949-43



2.5*6PWM6 Screw assembly

A949-49



M3 Loose nut assembly

A959-B-15



Motor teeth 27T group

1652



Battery assembly

L959-54



ST2.6*8KB screw assembly

L959-57



ST2.6*8PB screw assembly

L959-58

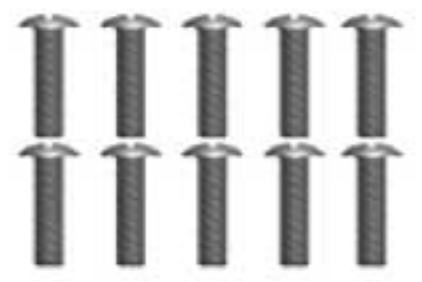

ST2.6*10PB screw assembly

1452

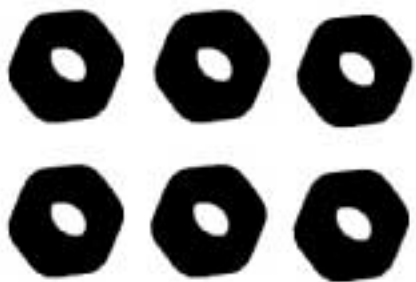

M3 flange nut

1389

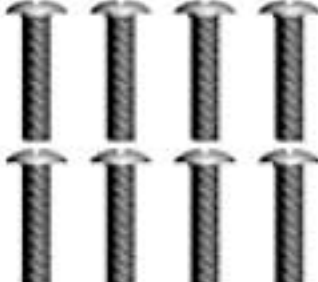

3 * 20pm Cross round head machine screw

1453

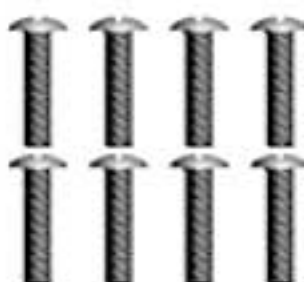

2*4PWM5 Cross round head machine screw

1656



2.5*8PWM6 Cross round head machine screw

Sale parts view

0416



ST1.7 * 4PB
screw assembly

0552



ST1.7 * 8PB
screw assembly

A303-32



ST1.7 * 6PB
screw assembly

0103



2.5 * 16 PM Cross pan
head screw group

0106



2.5 * 20PM Cross pan
head screw group

0104



2.5 * 14PM Cross pan
head screw group

0255



3 * 10PWM7
screw assembly

A303-38



3 * 14PM Cross pan
head screw group

1723



3 * 10KM Cross
countersunk screw group

1846

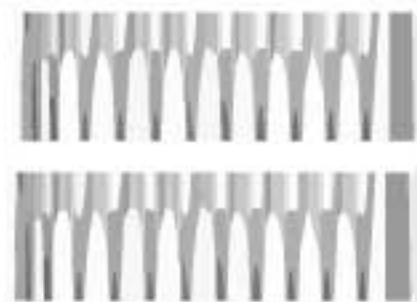

Rear shock spring set

1847



Rear shock absorber
axis group

1848



Rear shock block
axis group

1655



Shock proof sealing
cap 11 * 4.5 sets

1850



Rear shock absorber
assembly

1839



Central drive
shaft assembly

2008

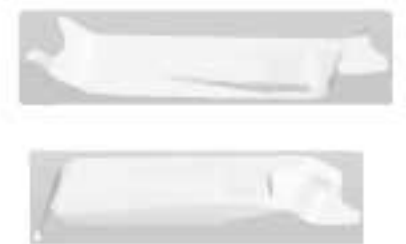

Left and right
sides of car shell

2009



Car head group

2010



Car roof cover group

2011



Seat group

2012



Cab rear seat group

Sale parts view

1975



Brushless receiver

1989



Zinc alloy cross sleeve group

Thank you for your support!



emida.top

More surprises start here

- END -